

HEWLETT-PACKARD JOURNAL

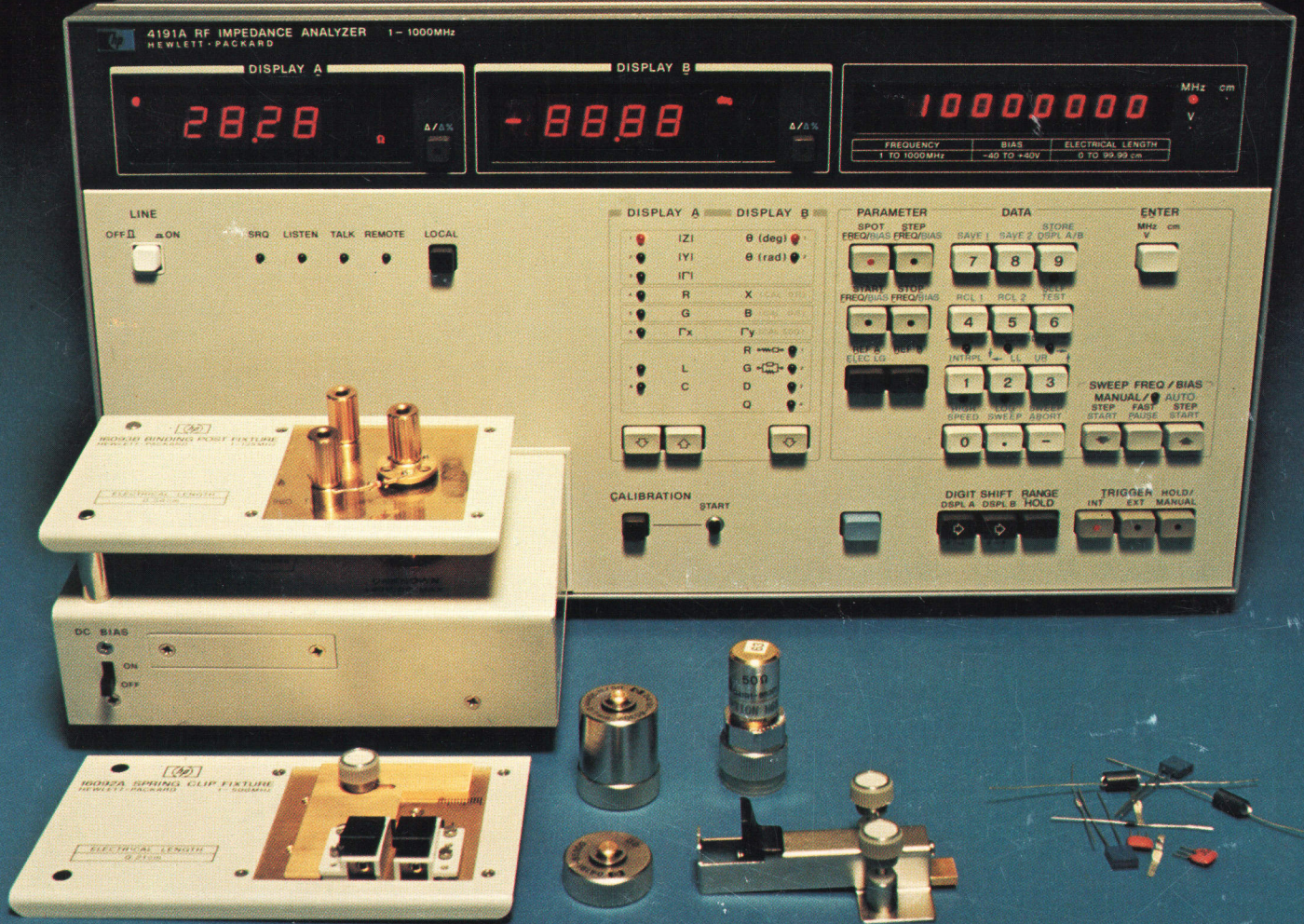

Contents:

3 Automated Testing of PCM Communications Equipment with a Single Self-Contained Instrument, by Robert Pearson, Mark Dykes, Virgil Marton, Andrew Batham, and Mike Bryant Simply by pressing a few keys, you can tell this instrument which of more than 60 telephone measurement routines to conduct automatically.

16 Software for an Automatic Primary Multiplex Analyzer, by Mark Dykes The built-in programs are at the heart of the Primary Multiplex Analyzer's capabilities.

22 Vector Impedance Analysis to 1000 MHz, by Toshio Ichino, Hideo Ohkawara, and Noriyuki Sugihara It measures materials and components faster, more accurately, and over a wider impedance range than previously available equipment in the UHF frequency range.

In this Issue:

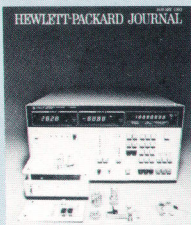

This month we feature two instruments that achieve a high degree of automatic operation by means of built-in microcomputers. The first, Model 3779A/B Primary Multiplex Analyzer (page 3), is designed to improve your telephone service. When you are talking to someone at a distant location, the electrical signal representing your voice goes through many switching points and transformations before being converted to audible conversation at the far end. If your conversation happens to go by way of a PCM (pulse code modulation) communications system, it is converted to a series of electrical pulses that carries the information needed to reconstruct your voice at its destination. PCM provides an economical means of sending signals long distances because it is possible to interleave (multiplex) the PCM pulse streams representing several conversations into a single high-density pulse stream. In fact, PCM in its early years was often used only to increase the capacity of existing telephone lines in congested areas. Now, however, new PCM installations outnumber new installations of FDM (frequency division multiplex) equipment in many countries, the reason being that digital (pulse) transmission offers many advantages that may lead to the evolution of a more efficient telephone network.

In any communications system there are many places where the conversation-carrying signal can be degraded, so telephone companies devote considerable attention to keeping the total degradation down to a level where it doesn't make your voice unintelligible. This effort requires myriad performance tests using a variety of test signals and various means of interpreting test results. Model 3779A/B performs these tests automatically. Its built-in microprocessor selects the test signals and interprets the results according to the desires of the technician using it. It's designed to test primary (first-level) PCM multiplex terminals more rapidly and conveniently than was possible before. It can also be used to test FDM terminals and TDM (time division multiplex) switching equipment.

Our cover subject, Model 4191A RF Impedance Analyzer (page 22) measures fundamental properties of semiconductor devices, electronic components, and electronic materials. Typical subjects for its measurement abilities are integrated circuits, microprocessors, diodes, transistors, capacitors, resistors, coils, transformers, ceramic and magnetic materials, printed circuit boards, filters, cables, and many other devices. The properties of all of these vary to a greater or lesser degree with the frequency of the electric voltages or currents applied to them, and one of the important benefits of the 4191A is that it measures over a wider frequency range and at much higher frequencies than previous impedance meters. It also measures a wider range of impedances and is more accurate than anything that's been available in its frequency range, a range that includes the FM and television broadcast bands (RF stands for radio frequency). Thus the 4191A makes a real contribution to a fundamental and necessary class of electronic measurements.

-R. P. Dolan

Automated Testing of PCM Communications Equipment with a Single Self-Contained Instrument

Microprocessor control of multiple sources and detectors within this compact instrument achieves a new level of automation for voice-channel measurements in PCM multiplex equipment.

by Robert Pearson, Mark Dykes, Virgil Marton, Andrew Batham, and Mike Bryant

IN RECENT YEARS, the telephone network has seen a substantial growth in both the number of subscribers and the rate at which subscribers use its services. This has prompted telephone operating companies to look to transmission and switching systems based on pulse code modulation (PCM) to provide the needed extra capacity. As a result, there has been a rapid growth in the manufacture and installation of PCM multiplex equipment, and a corresponding demand for instruments that can test it.

A large number of performance characteristics that should be met between the analog input and analog output terminals (A-A) of a PCM multiplex system has been recommended by the International Telegraph and Telephone Consultative Committee (CCITT) and other international

bodies working on the standardization of PCM systems. In addition, discussion continues on the digital aspects of the multiplex and although recommendations have so far been limited mainly to the encoding and decoding characteristics and the digital interfaces, it is clear that performance criteria for the transmit (A-D) and receive (D-A) halves will soon be defined. The development of an instrument that addresses itself to this large range of measurements—including many that are unique to PCM systems—has required a new approach to instrument design.

The Hewlett-Packard Model 3779A/B Primary Multiplex Analyzer, Fig. 1, is the result of this new approach. It is a complete measurement system containing both analog transmitter and receiver sections packed into a single en-

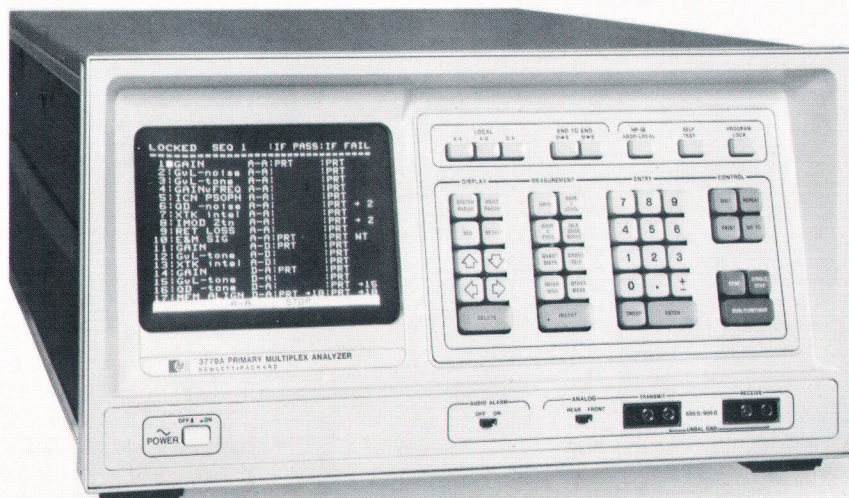

Fig. 1. Model 3779A/B Primary Multiplex Analyzer provides multimeasurement capability for testing PCM equipment. The 3779A shown here is intended primarily for European 30-channel PCM systems. The 3779B accommodates the North American 24-channel system.

PCM Transmission Systems

The telephone network has traditionally been an analog transmission system, but since the mid-1960's digital transmission systems based on pulse code modulation (PCM) have become established as an alternative to, or a substitute for, analog systems. The advantages of PCM are clear:

- Because of pulse regeneration in the repeaters, there is little progressive deterioration of a signal on long-haul transmissions, bringing long-distance telephone calls up to the standard of local calls.
- Signaling information (dial pulses, ringing and engaged tones, etc.) is easily handled, as is data traffic.
- Many channels (speech or data) can be time-division multiplexed to share the same cable pair, resulting in substantial savings in outside plant and an increase in network capacity to meet today's rapid growth in demand.

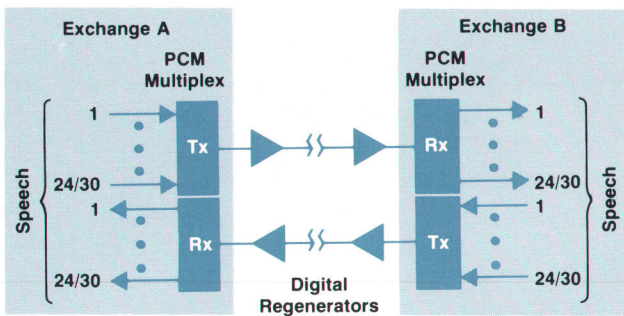

Fig. 1. In a basic PCM transmission system, the digital signal (PCM stream) between the multiplexes is regenerated at approximately one-mile (1.6-kilometre) intervals.

A basic PCM transmission system is shown in Fig. 1. The cable pair that used to carry one speech channel between two exchanges now carries 24 or 30. Since this cable was originally designed to handle signals that have a bandwidth of 3.4 kHz and now carries digital signals at 1.5 or 2 Mb/s, the line equalization networks have been removed and replaced by digital regenerators. The coding permits

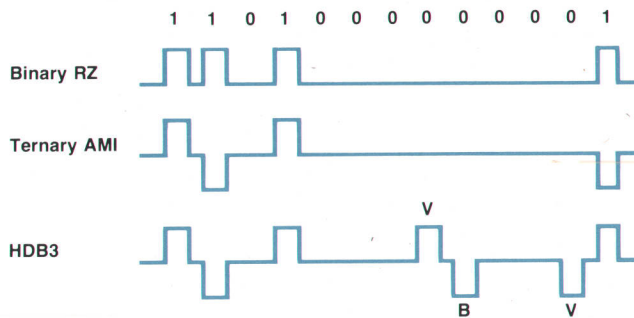

Fig. 2. The AMI (alternate mark inversion) line code eliminates the dc component in the signal, allowing dc power to be fed to the regenerators. Where no external clock is supplied, clock recovery from the signal is helped by using HDB3 (high density bipolar) coding, which eliminates long strings of 0's. Any four consecutive 0's are replaced by 000V or B00V where V is a recognizable code violation and B is a mark that is inserted to force successive violations to alternate in sign. In North America, it is more common to use AZS (all zero suppression) which replaces any digitized sample of eight 0's by 0000 0010 at the binary level.

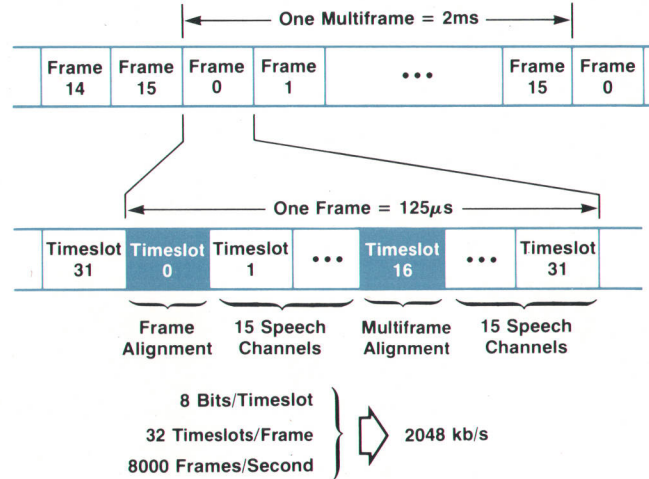

Fig. 3. The European 30-channel system uses a frame alignment signal in time slot 0 to identify each speech channel, and a multiframe alignment signal in time slot 16 to allow signaling information associated with each channel to be distributed throughout a 16-frame multiframe. The 3779A is designed to interface with this system.

dc power to be fed down the signal cable (Fig. 2).

A modern primary level multiplex samples each of 24 (North America) or 30 (Europe) audio speech channels at an 8-kHz rate. The samples are digitized and combined by time-division multiplexing into a serial digital pulse stream. On the receive side, the samples are demultiplexed and decoded back to analog signals.

A great deal of standardization has taken place on the details of the PCM equipment,¹ and two dominant systems have emerged, both based upon an 8-kHz rate for sampling the audio signals. Clearly, there have to be some identification bits in the PCM stream that enable the receive half of a PCM multiplex to decode the serial bit stream. Figs. 3 and 4 illustrate how this is achieved. In each case, only

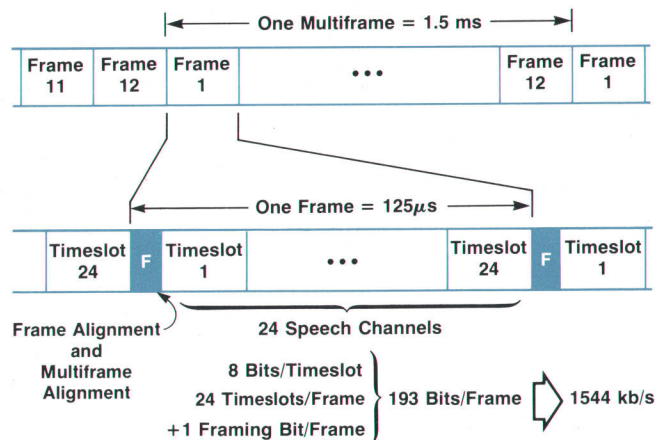

Fig. 4. In the North American 24-channel system, frame alignment and multiframe alignment information (more commonly referred to as terminal framing, F_T , and signaling framing, F_S) are both carried in a one-bit-per-frame sequence. Signaling information can be accommodated by stealing one bit per channel every 6th frame. The 3779B has been developed for this system.

eight bits per time slot are transmitted, but this represents the output of a 12- or 13-bit A-D converter that has been compressed to eight bits in a pseudo-logarithmic fashion. A complementary expansion (8 bits to 12 or 13 bits) is performed prior to D-A conversion in the receive half of a multiplex. In this way, the number of bits transmitted per channel sample is minimized while good signal-to-noise performance is maintained for a wide range of signal levels.

References

1. CCITT Orange Book Recommendations G.711, G.732, G.733.
2. K.W. Cattermole, "Principles of Pulse Code Modulation," Iliffe Books Ltd., 1969.

closure. Send signals include single tones, multiple tones, and band-limited noise. The receiver section has tunable narrow-band filters, a notch filter, several bandpass filters, and both average and rms detectors. Level control is by a programmable attenuator in the transmitter and autoranging in the receiver. The analog measurement capabilities of the 3779A/B are thus applicable to any voice channel, including FDM (frequency division multiplexed) equipment, although it is anticipated that the main use for this instrument will be in PCM systems.

Optional digital transmitter and digital receiver modules provide for A-D and D-A measurements. The digital transmitter generates a complete PCM frame format with selected time slots loaded with test patterns, while the digital receiver can align onto a PCM stream and extract information from the pertinent time slots. These options also fit into the mainframe.

By having this hardware designed around a microprocessor, the instrument's measurement capability has been much enhanced. The microprocessor controls the circuitry so as to perform a whole string of different actions (signal routing, filter selection, etc.) that together form a fully automatic measurement routine, such as swept frequency response. More than 60 different measurement routines, listed in Table I, are preprogrammed. The 3779A/B readily switches modes between A-A, A-D and D-A tests and a built-in data modem makes end-to-end (E-E) measurements between two distant instruments possible. Extensive self-test routines are also included.

The instrument is available in two versions. Model 3779A provides measurements according to CEPT (Conference of European Post and Telecommunications) recommendations while Model 3779B provides measurements according to Bell recommendations. Either one is powerful enough to automate production and acceptance testing while being sufficiently portable for use in commissioning and maintenance. Yet, they retain a flexibility in manual control that makes them useful to R and D personnel in the continuing development of PCM systems.

Multichannel Operation

PCM multiplex systems, usually called PCM multiplexes, are, by their very nature, multichannel devices and so the 3779A/B has been designed to drive the HP Model 3777A Channel Selector, a bidirectional 30-way switch, through the HP-IB.* An initial programming stage defines the parameters of each channel independently in respect of impedance, balance, relative levels at input and output, and

whether 2- or 4-wire. The instrument's processor refers to this list each time a channel is selected. Up to 256 channels may be specified this way, requiring control by the 3779A/B of nine or more 3777A Channel Selectors.

Although there are many ways of using the 3779A/B, a common measurement configuration for testing a PCM multiplex is shown in Fig. 2. During A-A tests, the PCM stream at the terminal output is looped through the 3779A/B from the optional digital receiver to digital transmitter back to the terminal input. By making the connections in this way, the 3779A/B can perform A-A, A-D and D-A tests without the need to recable for each mode.

Simplified Control

As a result of the advance of technology in recent years, it is now possible to gather in one instrument a large amount of measurement hardware. Just as in the case of an LSI chip, where the capability of the device becomes limited by the number of pins available rather than the internal circuitry, so does front-panel control of the functions of a modern

Table I. Measurement capabilities of the 3779A/B.

Measurements	A-A	A-D	D-A	E-E
Gain	•	•	•	•
High-accuracy gain	•			
Gain using peak codes		•		
Digital mW gain			•	
Gain vs frequency	•	•	•	•
Gain vs level using noise (3779A only)	•			•
Gain vs level using tone	•	•	•	•
Gain vs level using peak codes		•		
Gain vs level using sync 2-kHz			•	
Pedestal (coder offset)		•		
Idle channel noise psophometric (3779A only)	•	•	•	•
Idle channel noise C-message (3779B only)	•	•	•	•
Idle channel noise 3-kHz flat	•	•	•	•
Idle channel noise selective	•	•	•	•
Noise-with-tone	•			•
Quantizing distortion using tone	•		•	•
Quantizing distortion using noise (3779A only)	•			•
Intelligible crosstalk	•	•	•	•
Intermodulation using two tones	•			•
Intermodulation using four tones (3779B only)	•			•
Discrimination against out-of-band inputs	•			•
Spurious out-of-band outputs	•			•
Spurious in-band outputs	•		•	•
Return loss (Tx and Rx)	•			
Impedance balance (Tx and Rx)	•			
Signal balance	•			•
E & M signaling distortion	•			•
Analog level	•			
Digital level		•		
Remote alarms (3779A only)			•	
Multiframe alignment (3779A only)			•	
Frame alignment (3779A only)			•	
Local alarms (3779A only)			•	

*HP-IB: the HP interface bus, Hewlett-Packard's implementation of ANSI/IEEE 488-1978.

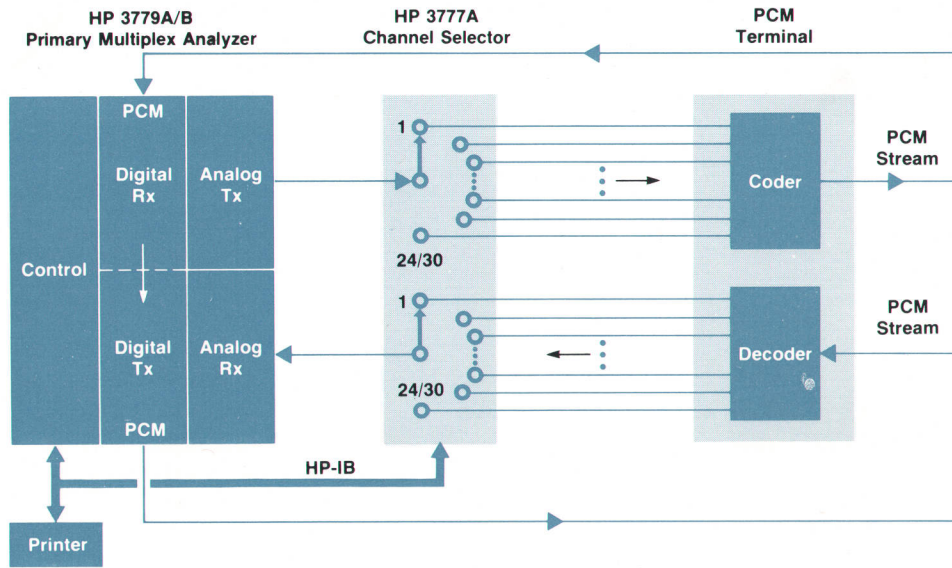

Fig. 2. A typical measurement configuration for A-A, A-D, and D-A testing of a PCM terminal. Control of the 3777A Channel Selector and a printer is entirely by the 3779A/B by way of the HP interface bus.

complex instrument become a real problem. The 3779A/B avoids the need for a potentially confusing array of dials and switches by using a special-purpose keyboard and an interactive CRT display. Ease of use is a major benefit resulting from this approach.

An important concept is that control of the 3779A/B is at the measurement level rather than the functional level. The user selects GAIN, for example, and enters frequency, level and so on instead of tuning an oscillator and setting an attenuator. An area of the front-panel keyboard (see Fig. 3) is designated MEASUREMENT. When the GAIN key is pressed, for example, a display is presented on the CRT that describes the measurement in terms of its parameters, in this case the number of channels to be tested, the signal frequency and level, and the result limits (Fig. 4). These default values for the parameters are preprogrammed, as is the structure of the measurement defining the selection of hardware functions and the sequence of actions within the measurement. Although the default values are stored in ROM the user can modify any parameter to suit the specific test procedure by using the cursor control keys to position

the cursor alongside the number of interest and pressing the numeric ENTRY keys.

Since the 3779A/B can perform so many measurements in each mode (A-A, A-D, D-A, E-E) a CRT display is used to permit a reduction in the number of MEASUREMENT keys. Each of the seven most-often-used measurements has a unique key while the OTHER MEAS key brings up the display of a list, or menu, of other measurements that are probably used less often. Fig. 5 shows the list for the other A-A measurements. Similar lists exist for A-D, D-A, and E-E measurements.

Microprocessor Control

The use of processor control in the 3779A/B gives several benefits in the running of measurements:

- The complete measurement runs automatically, performing a series of actions at each of a number of measurement points (e.g. different frequencies in a GAIN v. FREQ test) and, if required, repeating for each of a number of channels.

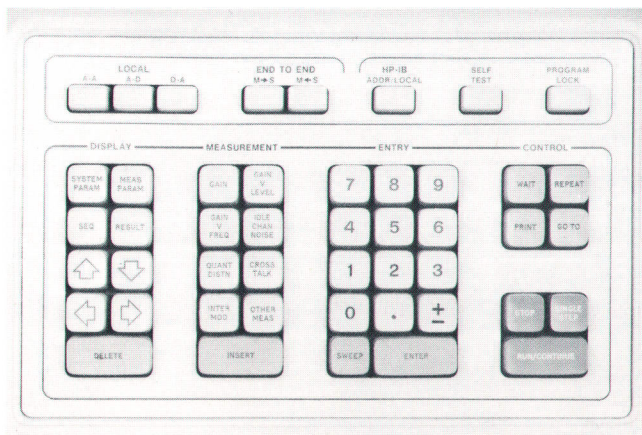

Fig. 3. The keyboard of the 3779A/B Primary Multiplex Analyzer.

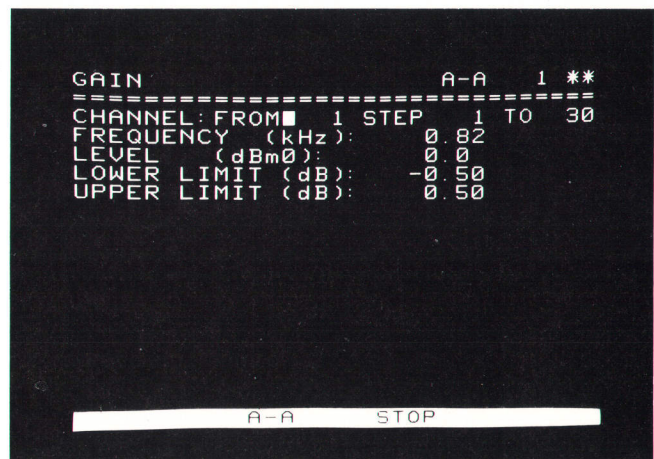

Fig. 4. The display of the measurement parameters for a GAIN measurement in the A-A mode. The white square is a cursor that is used to change parameter values.

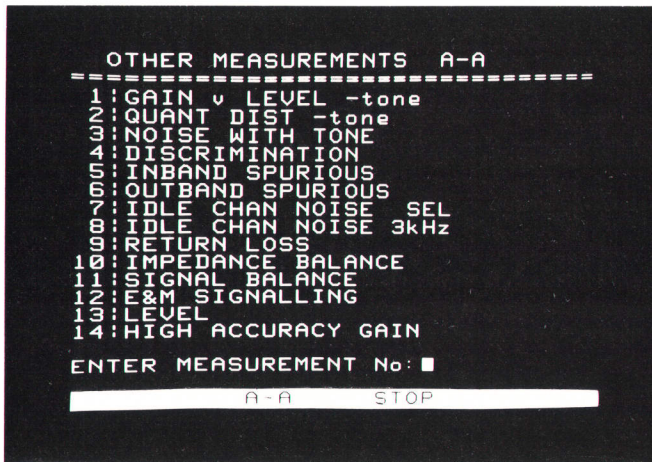

Fig. 5. Typical OTHER MEAS display lists the measurements available in addition to those included in the MEASUREMENT section of the keyboard.

- Arithmetic is performed automatically by the micro-processor to convert results to the most useful units, e.g. dB relative to ideal for a GAIN measurement, or dBm0p

- for psophometrically weighted idle channel noise.
- Testing is against programmed limits, with an indication of PASS or FAIL for each result.
- Pressing the PRINT key generates a fully formatted print-out of results on any 80-column, HP-IB compatible printer connected to the 3779A/B.

A nonvolatile memory in the 3779A/B allows for storage of a sequence of up to 68 measurements. By use of the INSERT key, any measurement with either default or modified parameter values can be added to a sequence. WAIT, REPEAT, PRINT and GO TO instructions, conditional on measurement results, can be programmed (see Fig. 1) making the 3779A/B a self-contained automatic test system. Since the storage is nonvolatile, any programmed sequence is retained indefinitely, even with the instrument switched off. Measurements may be modified, deleted, or added to a sequence to suit a user's changing requirements, but for program security, this editing capability can be inhibited by using a four-digit numeric entry as a combination lock in conjunction with the PROGRAM LOCK key.

For cases where 68 measurements are insufficient, the contents of the memory can be transferred to and from the backup memory of an external controller (e.g., a cassette in a

Faster Results with Automatic Measurements

The automating of measurements is one of the main benefits to be gained from processor control in an intelligent instrument. The operator can be relieved of such tasks as setting frequencies, levels, etc., and these tasks can be strung together into a preprogrammed measurement routine.

Consider the quantizing distortion measurement outlined in Fig. 1. This measurement is performed according to the CCITT method¹ which is, briefly, to measure the noise present in a bandwidth of 800 Hz to 2300 Hz resulting from the quantization of a noise signal that is limited to a band of 350 Hz to 550 Hz. The result is the ratio of signal to total distortion power, with an appropriate correction factor to relate this to the full PCM channel bandwidth of 300 Hz to 3400 Hz. The recommended limits vary with the signal level.

With the measurement parameters defined in Fig. 1 the following steps are performed automatically by the 3779A/B for each of 30 speech channels:

- Instruct the 3777A Channel Selector to select the appropriate channel.
- Set up the interface conditions for that channel (i.e., 600Ω or 900Ω, balanced or unbalanced) and select the band-limited noise source as the stimulating signal.
- With reference to the dBr levels* of the channel under test, set the output signal level to -55 dBm0, the first point in the measurement "mask".
- In the analog receiver hardware, select the reference filter (350 Hz to 550 Hz), the rms detector, and a suitable gate time for the voltage-to-frequency converter, then measure the signal level at the output of the channel under test.
- Select now the measurement filter (800 Hz to 3400 Hz) and measure the level of distortion power at the channel output.
- Perform the appropriate arithmetic, including a bandwidth correction factor, and display the result in dB with an indication of PASS or FAIL relative to the mask limit.
- Repeat steps 4 to 6 for transmit signal levels of -50 dBm0, -45 dBm0, etc., as defined by the measurement mask, displaying the result for each signal level.

For measurement points lying within a sweep, e.g. -55 to -40 dBm0 and -25 to -10 dBm0 in Fig. 1, the appropriate measurement limit for each point within the sweep is calculated by the processor by interpolating between the limits specified for the sweep end points.

This measurement, running automatically, delivers results at the rate of about one every five seconds and will, therefore, characterize a channel with respect to the complete CCITT recommended quantization distortion mask in about one minute. This represents a considerable improvement over existing manual test arrangements.

Reference

- CCITT Orange Book Recommendation 0.131.

*Multiplex equipment signal levels are described in dBm0, where zero dBm0 is the level of a standard signal at that point in the system. The dBr level at, say, the input or output of a channel, is the difference between 0 dBm and 0 dBm0 at that point.

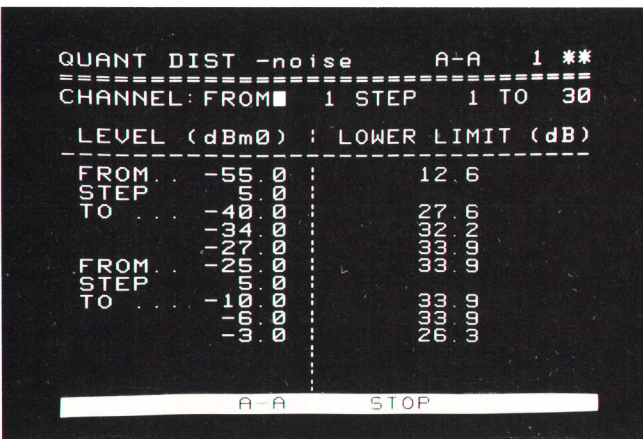

Fig. 1. Measurements can be defined in terms of a mixture of spot points and sweeps.

desktop computer), giving the ability to store an almost infinite number of sequences of measurements.

Analog Transmitter and Receiver

The analog measurement circuits, illustrated in the block diagram of Fig. 6, are simple in concept. Modular arrangement and bus-structured processor control provide flexibility of hardware configuration, allowing efficient use of circuits for many different measurements. Signal routing at medium impedance is by means of bipolar transmission switches fabricated in thick film to HP design.

The transmitter section provides band-limited pseudorandom noise (CCITT 0.131) in the 3779A or a four-tone signal (Bell Pubn. 41009) in the 3779B, in addition to single and double tones. The chosen output may be adjusted in level, impedance, and balance. It may also be routed to the receiver for calibration measurements.

The tones are generated by a synthesizer that is similar in concept to the synthesizer used in the HP Model 3770A Amplitude/Delay Distortion Analyzer,¹ but provides three programmable frequencies simultaneously. These are a MAIN and an AUXILIARY signal, for use in 2- and 4-tone intermodulation tests, and a local oscillator signal for the first mixer of the selective detector in the analog receiver. Equally spaced samples of each waveform are calculated and converted to an analog voltage that is retained in a

sample-and-hold circuit until the next sample for that waveform occurs. The frequency is changed by altering the incremental change of phase between samples. A single digital-to-analog converter operates on a sample every 750 ns to generate a signal that is switched sequentially to separate sample-and-hold circuits for each output. Each sample-and-hold is followed by a suitable filter.

The noise output originates in a pseudorandom binary sequence generator and has a spectral line spacing of 4.77 Hz.

In the receiver section, after impedance matching and autoranging, the raw input signal is passed through filters specified for the measurement. Tunable 12-Hz and 40-Hz bandwidth filters use three stages of mixing with a local oscillator signal and filtering and provide an output at 326 Hz. Notch and bandpass filter characteristics are specified by measurement standards.

The output from the filters is restored in level by an autoranging amplifier and converted to dc by squaring rms or averaging detectors with selectable time constants. Detection is followed by a voltage-to-frequency conversion that involves gating a 1-MHz clock to produce a count proportional to signal level.

A sine-to-square-wave converter that operates on the output of the autoranging amplifier, together with flexible counter control logic, provides combinations of clock and gating period that enable the counter to measure the level,

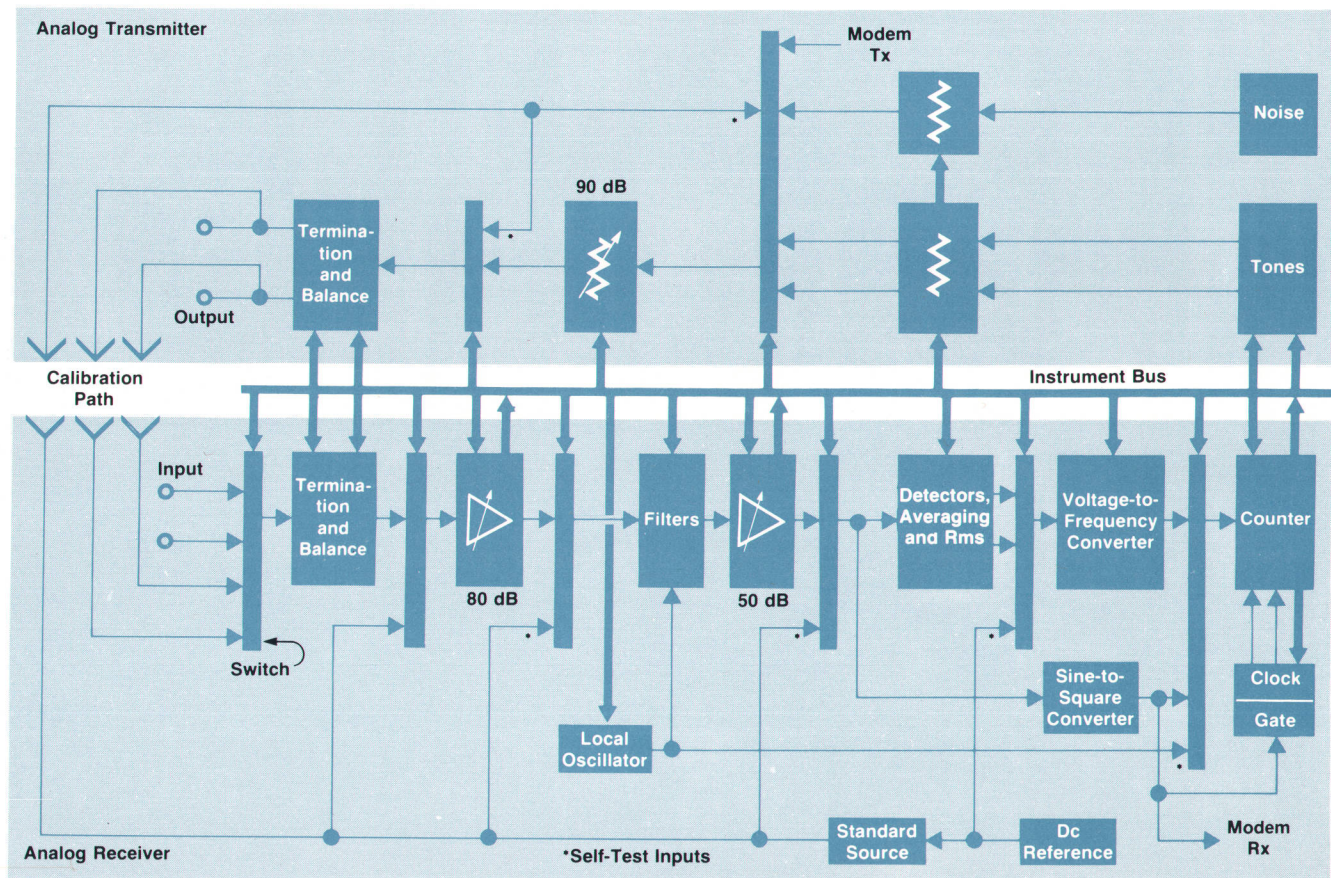

Fig. 6. Simplified block diagram of the analog Tx and Rx sections of the 3779A/B Primary Multiplex Analyzer.

End-to-End Measurements

Production or acceptance testing of telephone channel banks is usually done with the banks looped on themselves back-to-back. This arrangement, illustrated in Fig. 2 on page 6, requires only one 3779A/B.

Some installation and maintenance procedures require instead the testing of an actual channel between two points without far-end loop-around. This configuration involves separate transmitting and receiving ends with communication between the two. A pair of 3779A/B instruments can work together this way automatically, communicating over the channel under test. Measurements may be made in either direction and results may be displayed and/or printed at the master end (see Fig. 1).

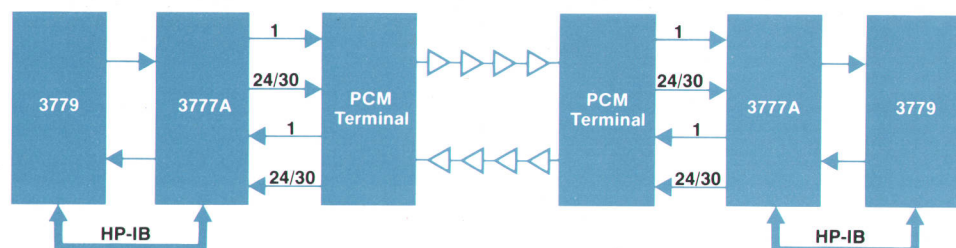

Fig. 1. End-to-end measurement setup.

In the 3779A/B, almost all A-A measurements may also be made end-to-end. The multichannel, sequence, and HP-IB control facilities are the same as for other modes. When the master instrument is given a RUN command, execution of an entire sequence can proceed automatically without operator intervention. The slave instrument may be unattended.

In the E-E modes, all software operations take place in the master instrument, which actually executes the measurement routines (Fig. 2). When a run begins, the master instrument first attempts to establish two-way communication with the slave, scanning all available channels until it receives a response. From the direction of testing, the master decides whether itself or the slave instrument is the transmitter, and accordingly directs the hardware commands either to itself or via communications routines to the slave. Commands, results and test signals are passed back and forth to complete the measurement. The slave instrument simply executes hardware commands as they are received and is unaware of the particular measurement being performed. No software operations are needed in the slave.

E-E Communication

The end-to-end capability of the 3779A/B requires no extra mea-

Master Action	Initiate Rx End	Initiate Tx End	Send Measurement Command	Transmit Test Signal	Send Acknowledgement	Calculate and Display Results	Send Stop Command	
Master to Slave Signal Path	COMMAND 1		COMMAND 2	TEST SIGNAL	ACKNOWLEDGEMENT		STOP	
Slave to Master Signal Path		ACKNOWLEDGEMENT		ACKNOWLEDGEMENT		RESULTS		
Slave Action	Execute Command 1	Wait	Wait	Send Acknowledgement	Execute Command 2 Measure Rx Signal	Transmit Results	Wait	Stop

Fig. 2. Automatic synchronization of E-E measurements.

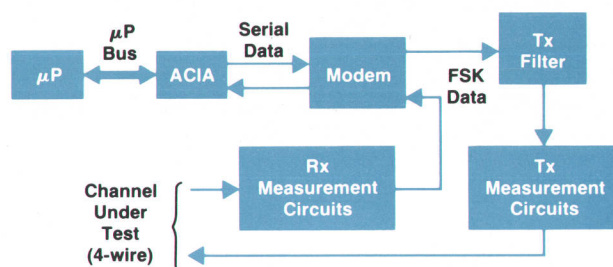

Fig. 3. End-to-end communications circuits.

surement circuits. Rather, it is based on information processing and control, and in a processor-based instrument these are easily provided.

Two standard IC chips and a simple filter are enough for the processor to transmit and receive asynchronous 600 bps FSK signals on the channel under test, using existing measuring circuits for level adjustment, channel matching, autoranging, filtering and sine/square conversion (Fig. 3).

The data carrier is detected by a software routine that exploits the flexibility of the analog receiver to check the level and frequency of the incoming signal.

Signal paths within the instrument are switched back and forth for measurement or communication as required, under processor control.

At the data-link level, the job of the processors at either end is to ensure reliable communication of messages. The line protocol is designed to tolerate delays and errors in transmission but if the noise or loss in a channel is too bad to permit communication, then both instruments will time out, re-establish communication on channel 1, and continue the measurements on the next good channel. A "channel skipped" message is printed for the faulty channel.

period, or frequency of the incoming signal.

Two forms of averaging are present in the receiver: the time constant of the detector, and the gating time during which the counter is enabled. For signals of known fixed period, e.g., pseudorandom noise or the 326-Hz output of the selective filters, measurements can be significantly speeded by using a short detector time constant and allowing the counter to integrate the varying detector output over an integral number of periods.

End-to-end communication over the channel under test is very simply added to the instrument since the existing measuring circuits are already under microprocessor control and are thus capable of being controlled by another instrument that communicates with the processor via built-in modems.

Measurement Accuracy

The instrument is designed to compare signals, for

example the signal received with that originally sent. Therefore, the receiver's gain linearity defines the accuracy of the instrument. The absolute level of the transmitter output and the absolute gain of the receiver chain are both irrelevant. The combination of primary autorange, averaging detector, and voltage-to-frequency converter together yields a basic accuracy of 0.04 dB for the comparison of two signals.

The instrument measures a signal in absolute terms by comparing it with a built-in ac reference available at the receiver input. This source is nominally 1 kHz at 3.535V rms, but if the user can measure its actual level to better than 0.02 dB, that value can be entered by way of the instrument's front panel for enhanced accuracy.

For self test, the circuit arrangements needed for measurement provide for back-to-back tests within the instrument. Extra signal paths are included for fault isolation.

A Digital Attenuator with 1-dB Steps

One of the requirements in D-A (digital-to-analog) testing in a primary multiplex is a digitized sine wave for frequency response and level testing. The frequency synthesizer in the 3779A/B generates digitized samples of a sine wave that are processed through a digital-to-analog converter for use as the stimulus in analog tests. The digitized samples are used directly for the D-A tests.

A second requirement is to manipulate the digitized samples to synthesize attenuation of the prototypal sine wave. In the digital domain, left-to-right shifts of each sample would synthesize attenuation in 6-dB steps. However, a meaningful test of a PCM decoder requires finer resolution than this. Level control over a 70-dB range in 1-dB steps was desired for the 3779A/B.

For a digital sample S, consider the following equations:

$$S - 1 \text{ dB} = 0.8912S \approx 0.891S \quad (1)$$

$$S - \frac{1}{16}S - \frac{1}{32}S - \frac{1}{64}S = 0.8906S \approx 0.891S \quad (2)$$

Thus, attenuation by 1 dB (i.e., multiplication by 0.891) can be achieved by subtracting from sample S a series of words that are themselves shifted versions of S. Expressions similar in form to equation (2) can be derived for other values of attenuation and, by accommodating up to 8 shifts (i.e. S/256), an accuracy of 0.03 dB can be realized. In the 3779A/B, the samples S are 12-bit words, so 20-bit arithmetic is used to handle the sample and its 8-bit-shifted versions.

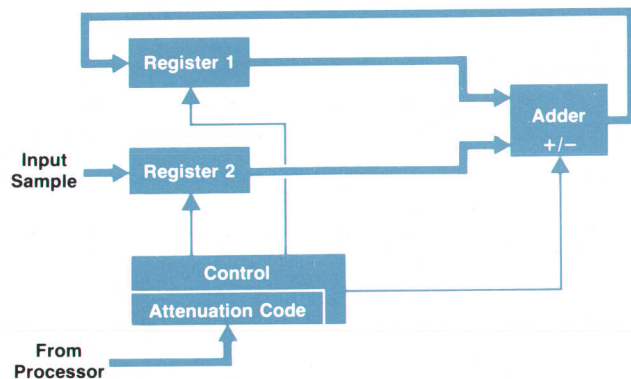

Fig. 1. Hardware organization for attenuating by shifting and adding.

To cover the large range of attenuations required, a "coarse-plus-fine" approach is used. Input samples are initially shifted to give a coarse attenuation in 6-dB steps, and a fine correction (+2 dB to -3 dB) is then applied. The complete operation can be defined mathematically as:

$$\text{OUTPUT} = S_S \left[1 \pm \left(c_1 \frac{1}{2} + c_2 \frac{1}{4} + \dots + c_8 \frac{1}{256} \right) \right]$$

Where S_S is the original sample S after shifting, and coefficients c_1 to c_8 have the value 0 or 1 as appropriate. It is worth noting that cumulative errors due to the approximation to 6 dB of each one-bit shift (instead of 6.0206 dB) can be cancelled in the fine attenuation stage.

Fig. 1 shows how the digital attenuator hardware is organized in the 3779A/B. An attenuation code word (Fig. 2) is generated by the processor for use by the control logic. The code word for 15-dB attenuation is shown in Fig. 2.

The control logic operates as follows:

1. Load register 2 with input sample S.
2. Right-shift register 2 according to the coarse attenuation field.
3. Clear register 1 and perform an ADD. Registers 1 and 2 both now hold the shifted sample S_S .
4. Right-shift register 2 and scan the fine attenuation coefficients ($c_1, c_2 \dots$) until a 1 is encountered.
5. Perform an addition or subtraction as defined by the ADD/SUB bit in the attenuation code word.
6. Repeat steps 4 and 5 until attenuation is complete.

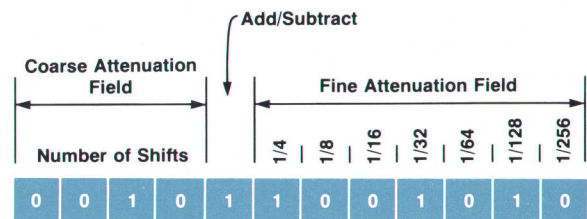

$$\begin{aligned} \text{Coarse: } 2 \text{ Shifts} &= 2 \times \text{"-6dB"} = -12.041 \text{ dB} \\ \text{Fine: } 1 - (1/4 + 1/32 + 1/128) &= -2.963 \text{ dB} \\ &= -15.004 \text{ dB} \end{aligned}$$

Fig. 2. The format of the attenuation code word, shown here for 15 dB. The 1/2 term is never needed and is not included.

Digital Transmitter and Receiver

Adding the optional digital transmitter and receiver to the 3779A/B provides the capability within one instrument of characterizing the analog-to-digital and digital-to-analog halves of a channel band separately. The digital ports of the instrument are designed to interface with the digital pulse stream conforming to the framing structures outlined in "PCM Transmission Systems," page 4.

Because of the marked differences between the European and North American systems it was necessary to define two different digital transmitters and receivers. Where the opportunity arises, however, as much commonality as feasible has been designed in. In a number of places wire links are used to program operation at the circuit-board level to either the European or North American standard, thus providing common boards for the 3779A and 3779B.

In both versions of the instrument, the digital receiver is designed to accept the digital pulse stream in the ternary alternate mark inversion form. The buffer amplifier on the digital inputs enables the 3779A/B to operate with cable losses of up to 6 dB. In addition, an extra 30 dB of gain may be inserted by means of a rear-panel switch to allow the instrument to operate with signals from a low-level monitor point.

The incoming pulses are buffered and converted from their ternary form to binary by means of two high-speed comparators. This binary stream is then fed to a clock extraction circuit consisting of an injection-locked oscillator whose output may be used both to extract the data from the pulse stream and as the master clock for the digital receiver. Alternatively, the master clock may be derived from an external clock input applied to the rear panel.

In many European primary-level PCM systems, a form of data encoding called HDB3 is used to suppress strings of zeros. The 3779A decodes this format in its digital receiver. North American primary level PCM systems do not use HDB3-type line codes. Instead, an AZS (all zeros suppression) binary code is used which, because it is binary rather than ternary, does not involve line code violations and is not detectable at the receive end.

Framing

The digital pulse stream in a PCM system has a very definite format or frame structure. Before any useful information can be extracted from the data stream it is necessary to align the receiver to the framing of the incoming signal. This is achieved by a synchronous state machine that can handle common channel signaling (CCS) or channel as-

E & M Signaling Measurements

Before any two subscribers can talk to each other over a telephone system, a signal path must be established between them. Information on the number dialed, along with ringing and busy signals and metering, has to be passed between exchanges. In a PCM link this is done by using the signaling channel associated with each voice channel.

Several types of signaling are in common use. The 3779A/B is designed to interface with the most common form, called E & M signaling. This form is a teletype-like signal based on two states: ON (input and output sink or source current) and OFF (input and output open circuit). Since a lot of signaling equipment is built with relays, the voltage level used is the full exchange battery voltage (about 50V). The battery voltage can be positive or negative, depending on the system, and the ON state may be asserted either by pulling the M input of the multiplex to ground, known as ground signaling, or pulling the M input to the battery voltage, known as battery signaling. Likewise the E output of the multiplex may go to battery or ground potential, depending on the system in use.

The 3779A/B tests the signaling channels of a PCM multiplex by

sending a square wave into the multiplex Tx input, M, and comparing it with the square wave received at the Rx signaling output, E. Any difference in the mark/space ratio of the received signal is regarded as signaling distortion which, if it becomes too high, could cause errors in the received data.

To avoid having the operator program into the 3779A/B exactly what voltage levels it should transmit and expect to receive, the 3779A/B carries out several tests automatically to ascertain the characteristics of the system under test before the actual measurement. These tests are as follows. First, the 3779A/B Tx output, M (on the rear panel), is set open circuit and the state of the 3779A/B Rx input, E (also on the rear panel), is monitored and stored as the OFF level. Next, the M output is pulled to ground. If the E input changes state, then the multiplex uses ground signaling and the new state of the E input is stored as the ON level. However, if there is no reply, then the M output is pulled to battery potential. If the E input now changes state, then the multiplex uses battery signaling and the new state of the E input is stored as the ON level.

If there was no change of state for either of the above then there is a

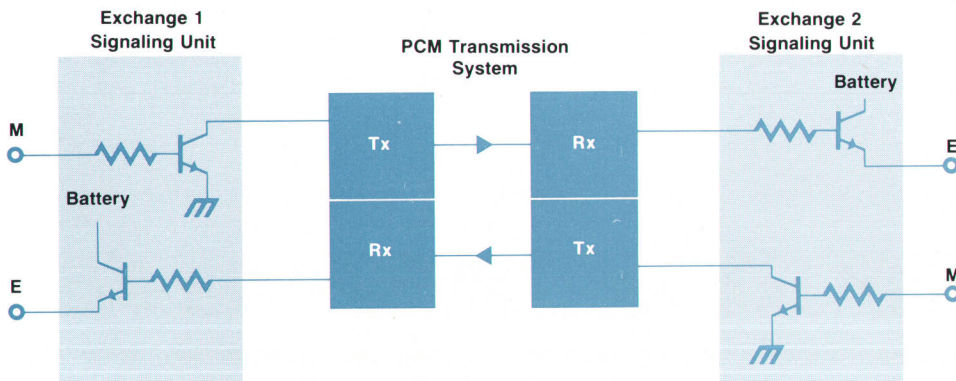

Fig. 1. Simplified E & M system.

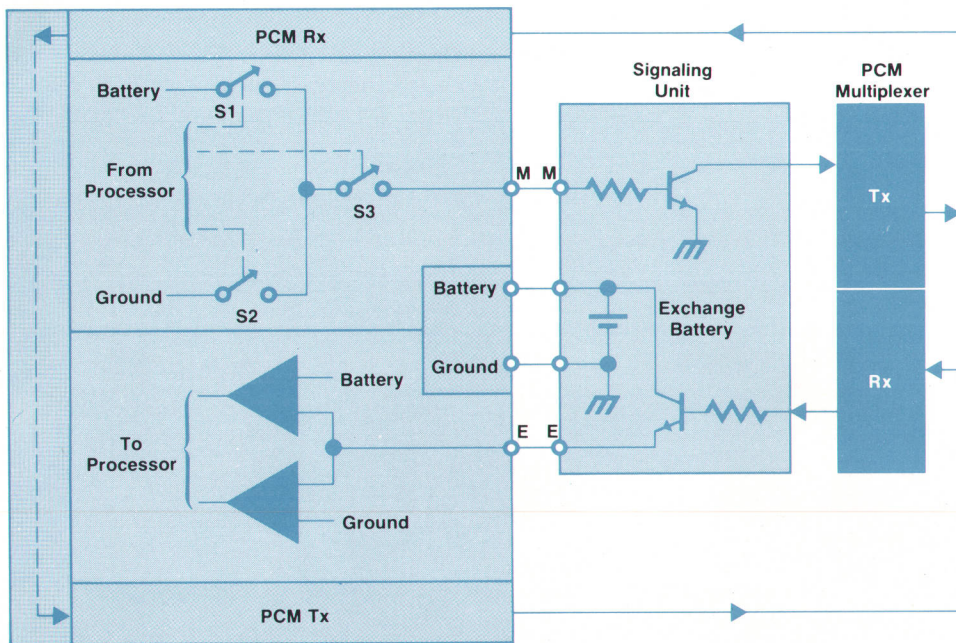

Fig. 2. E & M test set up in the 3779A/B.

If a satisfactory reply to one of the transmitted levels is received, then the signaling measurement begins. A square wave programmable in frequency and mark/space ratio is transmitted from the 3779A/B M output using either ground or battery as the ON state depending on the result of the earlier test. The E input of the 3779A/B looks only for the ON and OFF levels it previously remembered, thus eliminating spurious results due to spikes or relay contact bounce. The mark/space ratio of this reconstructed square wave is timed and calculated by the processor and the result displayed on the CRT.

Because of the low data rate in the signaling channels—each channel is selected once every 2 ms in CEPT systems and once every 1.5 ms in Bell systems—there will be jitter in the rising and falling edges of the square wave. By averaging over several samples, the delay in both the rising and falling edges will converge towards the same limit, thus tending to cancel out this source of error.

A simplified E & M system is shown in Fig. 1. When the M input of Exchange 1 is connected to the battery voltage (battery signaling), the signaling bits in the PCM send link for that channel are set. These bits are decoded in the multiplexer of Exchange 2 and the output transistor is turned on, pulling the E output high. Exchange 2 signals back in a similar fashion.

A simple test setup is shown in Fig. 2. This arrangement can be extended to multichannel measurements by using a 3777A Channel Selector. The equivalent circuit of the 3779A/B signaling tester is shown. The processor selects either ground or battery signaling by enabling either S1 or S2, and generates the required code by turning the output on and off at the required rate using S3. The 3779A/B signaling receiver consists of two comparators that inform the pro-

cessor of the voltage level at the E input.

To allow for positive or negative battery voltages, each switch is a solid-state bidirectional switch of the type shown in Fig. 3. The control line in Fig. 3 turns on the transistors by way of the optoisolator. For positive voltages at the input, the current flow is through diode D1, transistor Q2, and diode D4 to the output. For negative voltages, current flow is by way of D3, Q2 and D2.

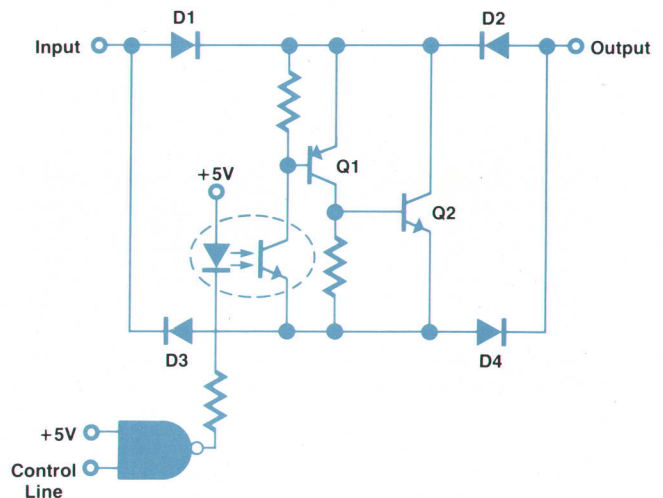

Fig. 3. Bidirectional switch accommodates battery voltages of either polarity.

sociated signaling (CAS) formats, depending on the position of an internal link.

Because of the differences between the European and North American frame formats, this is one area that requires two separate circuits. For European PCM systems, the criteria for determining gain and loss of frame and multiframe alignment are exactly defined in CCITT recommendation G.732 and these criteria are adhered to in the 3779A.

For North American PCM systems, no such well defined standard exists. In the 3779B, if three or more alignment bits are in error in a group of eight alignment bits, frame alignment is then considered lost and is regained only after a run of six correct alignment bits. In the case of channel associated signaling, multiframe alignment is also monitored and is considered lost if frame alignment is lost or if two consecutive multiframe alignment bits are in error. It is

regained only after a run of twelve consecutive multiframe bits are received correctly.

Once frame alignment, and if necessary multiframe alignment, has been achieved in the receiver, data may be extracted from the time slot of interest. This data can be analyzed in digital form by the instrument's processor or can be passed to the analog receiver via a D-to-A converter that operates on the bits corresponding to low-level signals. Converting the low-level signals to analog form has the advantage that the complex weighting filters already present in the analog receiver may be fully used for "digital measurements" on noise and crosstalk.

In addition to extracting the data from the PCM pulse stream, the digital receiver also provides a number of flags to the processor so that the status of the incoming signal may be monitored. These include flags for loss of signal, loss of clock, loss of alignment, and the alarm indication signal (AIS) from the system under test, any of which could result in an invalid measurement if not detected.

Test Signals

To perform D-A measurements, the digital transmitter can generate a ternary PCM stream to the required format: 2.048-MHz 30-channel for the European 3779A, or 1.544-MHz 24-channel for the North American 3779B. Test data may be inserted into this PCM stream depending on the measurement to be made.

For tone-based tests (GAIN, GAIN V. FREQ., etc.) a digitally encoded sine wave is obtained from the frequency synthesizer before the digital-to-analog conversion. It is selectable in frequency and level (see "A Digital Attenuator with 1-dB Steps," page 10) and may be inserted into any one time slot under processor control. Alternatively, data generated directly by the processor may be inserted into the time slot. This latter facility is used for such measurements as CCITT 1-kHz GAIN or 2-kHz GAIN V. LEVEL where the coded audio signal must be synchronous with the frame rate, or in frame and multiframe alignment tests (3779A only) where a number of different data strings are required and the reaction of the equipment under test must be monitored.

For all measurements the data in the channels not under test—the "background PCM"—may be derived from one of two sources. Either the digital transmitter generates the complete PCM stream or it takes the signal presented to the digital receiver and retransmits it with the required test signal inserted in it. Internally generated background PCM usually is a pattern nominally equivalent to that generated by an idle channel, but for frame alignment tests, it consists of a pseudorandom binary sequence to simulate traffic.

The ability to retransmit the received PCM stream allows the user to generate any other background analog signal that may be desired, such as when measuring crosstalk. More importantly, it allows the digital path to be accessed for A-D and D-A tests or looped for A-A tests without the need to recable the instrument and equipment. With the transmitter running in this looped mode, its crystal oscillator is disabled and the transmitter clock is derived from the receiver clock to maintain synchronization.

A further feature of the 3779A digital transmitter is its ability to generate the HDB3 line code if required. Similarly, the 3779B can suppress the all-zeros codes for North

American systems.

Single-Channel Codec Testing

In anticipation of the needs of current developments in single-channel codecs and TDM (time division multiplex) switching equipment, a TTL interface is provided in the digital option. The data (Tx and Rx) is arranged as an 8-bit parallel or serial signal together with a synchronization signal at an 8-kHz rate. This general-purpose form enables simple external interface circuitry to be built for specific applications.

Self Test

For self-test purposes, a means of automatically looping the transmitter output back into the receiver is provided. By using this looped signal along with the various flags generated in the digital receiver, the instrument processor is able to test both the digital receiver and digital transmitter to a high level and isolate most malfunctions to a section of circuit.

The Processor System

The processor chosen to control the PMA is HP's CMOS/SOS 16-bit parallel microcontroller chip (MC²), a high performance, low power consumption device.² Due to the relatively large number of real-time tasks involving manipulations of the PCM data performed by the 3779A/B, this processor replaces a large amount of dedicated digital hardware.

The processor section of the 3779A/B consists of the basic units of any computer system. The internal storage consists of:

- 768 words of fast RAM (1 word = 16 bits), which is part of the processor board.
- 1024 words of nonvolatile RAM consisting of well-proven ferrite cores, housed on a separate board.
- 1024 bytes of DMA display RAM.
- 32K words of 2K × 8 PROMs for system control and measurement routines.
- 2048 words of ROM available on the processor board for self-test purposes.

The 3779A/B is programmed manually from a keyboard using an interactive display as a visual feedback device. The keyboard was implemented as a scanned matrix and uses the interrupt system to communicate with the processor. The display is based on a character generator that translates the ASCII characters contained in the 1K-byte memory (to which the processor writes using the DMA technique) to a 9 × 7 dot matrix. The display memory provides the character codes needed for printing any display dump.

The processor controls the rest of the instrument via an instrument bus that is completely buffered from the processor bus. The instrument bus consists of six address lines, 16 data lines and one control line (strobe) and is regarded as part of the processor's I/O bus.

The 3779A/B can also communicate with the outside world. There are two basic means of establishing this communication:

1. By way of the HP-IB, using the processor-to-HP-IB interface chip (PHI).³ This LSI device is part of the same CMOS/SOS family as the microprocessor itself. The

HP-IB enables remote control of the 3779A/B as well as allowing the 3779A/B to control its own satellite devices (scanners, printer).

- By way of the modem. An asynchronous, 600-bit/s modem is used by the 3779A/B to communicate with another 3779A/B on the line under test in order to perform the END-END class of measurements. A commercially available FSK modulator/demodulator (MC14412) is used in conjunction with an asynchronous communication interface adapter (MC6850).

The HP-IB communicates with the processor using the interrupt system, whereas the modem input is continually scanned while the processor is in its idle loop.

All processor boards communicate via the processor bus which consists of 16 address lines, 16 data lines, and 9 control lines. This bus is completely self-contained to ensure microprocessor availability for fault detection and location for the rest of the instrument. The microprocessor

chip itself together with 2K words of ROM is buffered from the rest of the processor bus so it can be used to check the remaining components of the processor system individually. In this case, tests are controlled from a set of dual-inline switches on the processor board while four LEDs encode the results of different tests.

Acknowledgments

Clearly, many people are involved during the development cycle of a product of this size and complexity. The authors would like to note the contribution of Rod May in providing broad technical experience as project leader during the definition of the product and through to the lab prototype stage, and of Dave Leahy who deserves credit for the elegant and efficient packaging of the instrument. Robert Duncan and Alastair Sharp were responsible for the design of most of the analog transmitter and receiver sections, and Robin Mackay (product design) and David Guest

ABRIDGED SPECIFICATIONS

HP Model 3779A/B Primary Multiplex Analyzer

Standard instrument provides analog-analog and end-end measurement capability. Analog-digital and digital-analog capabilities are optional. The measurements are summarized in Table I, page 5.

Analog Transmitter

SINGLE TONE: 40 Hz to 40 kHz, ± 50 ppm; 10-Hz resolution.
PAIRS OF TONES: 40 Hz to 4 kHz, ± 50 ppm, 10-Hz resolution.
HARMONICS, SPURIOUS TONES: < -55 dB.
FLATNESS: ± 0.01 dB (200 Hz to 4 kHz);
 ± 0.05 dB (40 Hz to 10 kHz);
 ± 0.3 dB (40 Hz to 40 kHz).
NOISE SOURCE (3779A only): Meets CCITT Rec. 0.131.
4-TONE SOURCE (3779B only): Meets BSTR 41009.
MAXIMUM OUTPUT LEVEL: $+13$ dBm ± 0.2 dB (tones);
 $+5$ dBm ± 0.2 dB (noise).
MINIMUM OUTPUT LEVEL: -76.9 dBm.
LEVEL RESOLUTION: 0.1 dB.
IMPEDANCE (balanced or unbalanced): 600 Ω or 900 Ω .
MAXIMUM DC ISOLATION: ± 56 V.

Analog Receiver

MAXIMUM AC LEVEL: 12V p-p.
MAXIMUM DC LEVEL: ± 56 V.
IMPEDANCE: 600 Ω or 900 Ω .
NOISE FLOOR: < -100 dBmp.
SELECTIVE FILTER: 12-Hz or 40-Hz bandwidth.
3-kHz FLAT FILTER: Meets BSTR 41009.
QUANTIZING DISTORTION: Meet CCITT Rec. 0.131.
PSOPHOMETRIC FILTER: Meets CCITT Rec. P.53. } 3779A only.
NOTCH FILTER: 810 Hz. }
4-TONE INTERMOD FILTERS: Meet BSTR 41009. } 3779B only.
C-MESSAGE FILTER: Meets BSTR 41009. }
NOTCH FILTER: 1010 Hz. }
INTERNAL STANDARD SOURCE: 3.535V rms $\pm 0.2\%$.

E & M Signaling

OUTPUT
SIGNAL FREQUENCY: 5 Hz to 20 Hz, 1-Hz resolution.
DUTY CYCLE RANGE: 20% to 80%, 10%-steps.
MAXIMUM DC RANGE: ± 56 V.
MAXIMUM CURRENT OUTPUT: ± 100 mA.

INPUT
INPUT IMPEDANCE: 50 k Ω to $\frac{1}{2}V_{battery}$.
DC OPERATING RANGE: ± 56 V (maximum), ± 20 V (minimum).
INPUT SIGNAL FREQUENCY: 5 Hz to 20 Hz.
ALLOWABLE CONTACT BOUNCE: 3 ms (maximum).

Digital Transmitter

PCM FRAME FORMAT: Meets CCITT Recommendation G.732 (3779A) or Recommendation G.733 (3779B).
SIGNALING: CAS or CCS.
CODING: HDB3 or AMI (3779A); AMI or AZS (3779B).
OUTPUT IMPEDANCE: 75 Ω unbalanced (3779A); 100 Ω balanced (3779B).
SYNTHESIZED TONE TEST SIGNAL:
FREQUENCY RANGE: 40 Hz to 3.5 kHz, ± 50 ppm, 10-Hz resolution.

LEVEL RANGE: $+3$ to -64 dBm0, 1-dB resolution.
COMPRESSION CHARACTERISTIC: A-law (3779A); μ -law (3779B).
OTHER TEST SIGNALS: Processor-generated 8-bit words at maximum word rate 1 word/frame.
TEST SIGNAL LOCATION: Any one time slot.

Digital Receiver

PCM FRAME FORMAT: }
SIGNALING: } As for Digital transmitter.
CODING: }
INPUT IMPEDANCE: }
RECEIVER CLOCK: Recovered or external.
FRAME ALIGNMENT: Automatic.
MULTIFRAME ALIGNMENT (CAS only): Automatic.
TEST SIGNAL SELECTION: Contents of any one timeslot.
MAXIMUM WORD RATE: 1 word/frame.
TIMESLOT TRANSLATION MAPPING:
 3779A: Contents TS(n), TS(n+16) exchanged.
 3779B: Contents TS(n), TS(n+1) exchanged, for n an odd number.

Single-Channel Interface

FORMAT: 8 bits serial (or parallel) + sync signal.
WORD RATE: 1 word/frame.
LEVELS: TTL.
INPUT IMPEDANCE (each line): 100 Ω to 3.5V.

General

POWER SUPPLY: 115/230V ac, $+10$ -22% , 48 to 66 Hz, 150 VA.
SIZE: 234 mm H \times 426 mm W \times 603 mm D (9.3 \times 16.8 \times 23.8 in).
WEIGHT: 25 kg (55 lb).
OPERATING TEMPERATURE: 0 to 55 $^{\circ}$ C.
CONNECTORS:
 ANALOG TX, RX (front and rear): 3-pin Siemens (3779A); WECO 310 (3779B).
 E & M SIGNALING: Binding posts.
 STANDARD SOURCE OUTPUT: 50 Ω BNC.

Options

3779A OPTION 001:
 As 3779A standard, plus digital TX, RX.
CONNECTORS: 75 Ω BNC (all PCM interfaces); 37-way D-type (Single Channel Interface).
3779A OPTION 002:
 As 3779A Option 001, except replace all 75 Ω BNC connectors with Siemens 1.6 mm 75 Ω .
3779B OPTION 001:
 As 3779B standard, plus digital TX, RX.
CONNECTORS: WECO 310 (all PCM interfaces); 37-way D-type (Single Channel Interface).
PRICES IN U.S.A.: Model 3779A/B, \$22,810; opts 001 and 002, \$2285.
MANUFACTURING DIVISION: HEWLETT-PACKARD LTD.
 South Queensferry
 West Lothian EH309TG
 Scotland

(analog circuits) helped ease the instrument into production. Continuous support in a variety of tasks came from Andy Horsburgh and Dave Jelfs with Stuart Ross and, latterly, Colin Deighton covering production engineering considerations. Of the many others who contributed, mention must be made of Peter Hockett, who was involved in the definition stage and has covered the market aspects, and of George Cooper for his many inputs regarding the testing of the instrument.

References

1. D.H. Guest, "Simplified Data-Transmission Channel Measurements," Hewlett-Packard Journal, November 1974.
2. B.F. Forbes, "Silicon-on-Sapphire Technology Produces High-Speed Single-Chip Processor," Hewlett-Packard Journal, April 1977.
3. J.W. Figueroa, "PHI, the HP-IB Interface Chip," Hewlett-Packard Journal, July 1978.

Andrew Batham



Born in Surrey, England, Andy Batham gained his B.Sc. from the University College of North Wales before joining HP at South Queensferry, Scotland in 1973. He worked in R & D on a number of projects before joining the 3779A/B team to tackle the digital hardware. Andy, who is married and has two young children, has spent much of his spare time recently building a garage. He also enjoys orienteering and boating when car and house repairs permit.

Mark Dykes

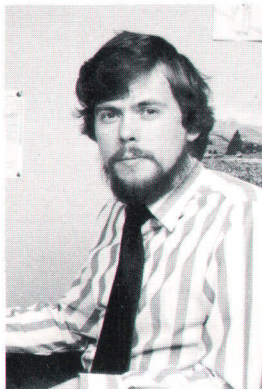

A native of Glasgow, Scotland, Mark Dykes studied engineering at Jesus College, Cambridge (MA), and management at Glasgow University (DMS). Joining HP Ltd. in 1973 at the inception of the 3779 project, he contributed hardware to early prototypes before working on support and applications software for the final versions. Outside HP, Mark enjoys singing classical choral works and can be persuaded to give a "blaw" on the bagpipes. A lot of his time goes to helping run youth camps and working with a variety of Christian organizations. In the summer,

Mark likes visiting his grandparents in Switzerland or navigating England's historic canal system in a traditional sixty-foot narrowboat.

Mike Bryant



Mike Bryant joined HP in 1977 after receiving his B.Sc. in electronic engineering at Southampton University. He worked on the digital part and some of the measurement software of the 3779A/B. Twenty-three and single, Mike's main interest is car rallying. He is presently building a new rally car and looking for sponsorship to enable him to compete in the British Forest Rally Championship. His other interests include rock music and modern ballet.

Robert Pearson

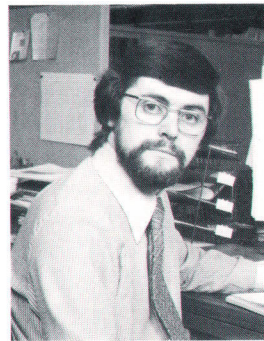

Rob Pearson joined HP at South Queensferry in 1973 and worked on the 3780A Pattern Generator/Error Detector. He became project leader for the 3779A/B after being involved in the early work on its digital hardware and related measurement software. Rob is a graduate of Glasgow University (B.Sc.) and Heriot-Watt University, Edinburgh (M.Sc.). In his spare time he plays golf and badminton and is self-sufficient in home-brewed beer. Rob and his wife have one son and one daughter.

Virgil Marton

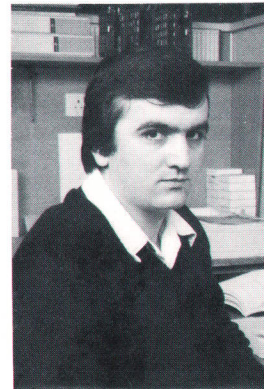

Virgil Marton was born in a remote corner of Transylvania (Romania) and came to Britain in 1968 to study computer science at Manchester University. After graduation, he worked in computer system design for a large mainframe manufacturer. When he joined HP Ltd. in 1976, the 3779A/B was just entering its lab prototype stage and his main work was on the micropocessor control of the instrument. Since then, he has worked on an investigative project in data communication. During the holidays, Virgil and his wife enjoy visiting different wine-producing countries and joining in the local customs. Otherwise, reading and nature walks fill most of his spare time.

Software for an Automatic Primary Multiplex Analyzer

by Mark Dykes

THE SOFTWARE in the 3779A/B had to meet two objectives: (1) to add intelligence to the powerful hardware to furnish high-level solutions to specific measurement problems; and (2) to provide a friendly front panel that nevertheless allows the operator access to the full potential of the instrument. The control program is therefore quite complex, occupying 34K words of 16-bit memory. The main elements of the program are:

- The keyboard/display operating system
- Data tables
- The measurement package
- The self-test package
- The HP-IB package.

Apart from the table area, the memory contains two kinds of code. Central service, speed-critical, and processor self-test routines are assembled into machine code. The measurement package and instrument self-test routines are written in a high-level language and compiled into intermediate code that is interpreted as it is run.

Traditional instruments measure continually, and their controls can be altered while they are running. The 3779A/B, by contrast, is a menu-controlled instrument with RUN and STOP keys. After switching the instrument on, it is normal to program it as desired (in the STOP state), and then to press the RUN key. The measurement(s) specified are carried out (in the RUN state), and afterwards the instrument reverts to the STOP state. This division is basic to the organization of

the control program.

The Keyboard-Display Operating System

The 3779A/B is capable of more than 60 measurements with different types and numbers of parameters (i.e., level, frequency, limits, etc.). It can contain descriptions of 256 channels, store up to 68 measurements in user-defined sequences, and keep information on the test and HP-IB configurations. Because of the volume of information to be handled, the entry and display system is cursor-controlled and highly interactive.

Information is entered by calling up the appropriate display and moving the cursor alongside the field of interest. As a value is keyed in, the numeric entry routines continually check it against upper and lower limits, and prompt the user with a message containing the relevant limit value if a mistake is made. In this case, the cursor freezes and flashes, and display changes are inhibited if necessary until a correct entry is made.

Keys are provided to edit parameter masks and measurement sequences, and a FROM-STEP-TO format is available for swept parameters.

The mode and control states of the 3779A/B are always present in inverse video at the bottom of the screen.

Data Tables

The details of display formats are held in ROM in the form

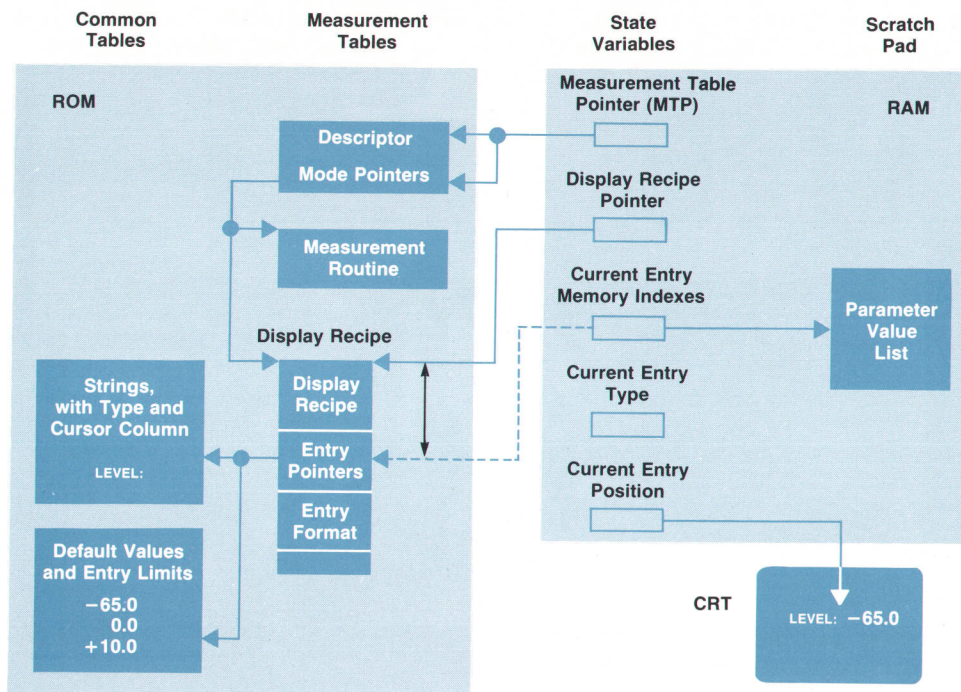

Fig. 1. Display recipes direct the assembling of data for presentation on the CRT.

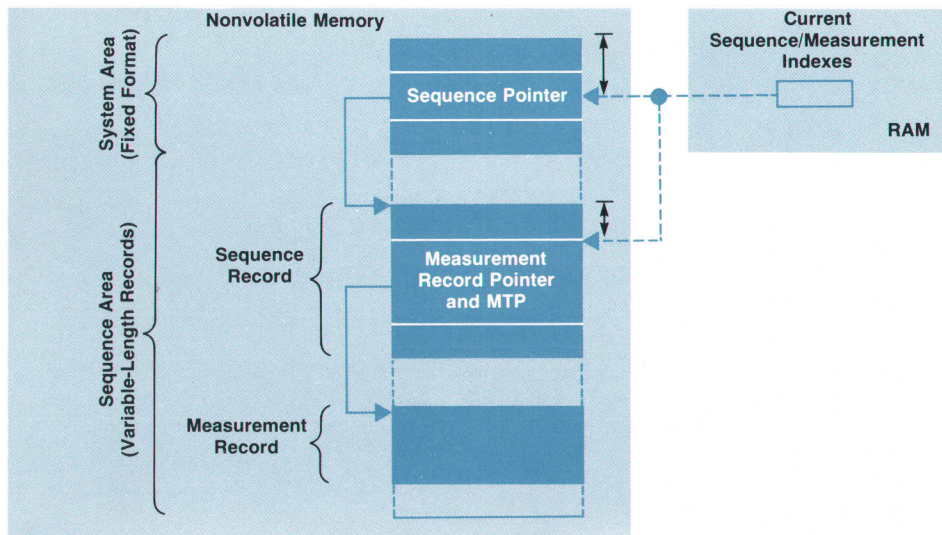

Fig. 2. The nonvolatile read-write memory holds variable-length sequences that can be linked to make one long sequence.

of display recipes that are designed to be efficient for the more common types—allowing sharing of strings and so on—but that are also flexible to accommodate exceptions.

The first step in calling up a new display is to create a list of the requisite numeric values in a scratchpad area of RAM (Fig. 1). For a new measurement display, these values are default parameter values extracted from ROM via the display recipe, also in ROM. Thereafter, a common routine reads the display recipe in conjunction with the parameter list associating strings and numbers on the CRT screen. After the display is complete, keyboard modifications to the numbers displayed are also recorded in the scratchpad.

If a measurement display is present and a RUN command is given, the relevant measurement routine is found through the measurement table, and run in accordance with the associated descriptor.

A measurement in the scratchpad can be run as described, or saved by storing it in the sequence area in nonvolatile memory (Fig. 2). This area is organized as four sequences of 17 measurements that can be linked together to make one long sequence. Because sequences vary in length and measurements have different numbers of parameters, the sequences are stored as records of arbitrary length. The number of measurements that can be stored depends on their complexity, because the size of the nonvolatile memory (NVM) is limited. The sequence area is repacked whenever a measurement is deleted from a sequence.

A portion of the NVM is used as a system area. This area contains information like the HP-IB address of the instrument, the user-measured value of the instrument's standard source, channel descriptions, and other test configuration data. An interesting feature is the software lock mechanism, designed to prevent unauthorized alteration of user-defined information. Combinations can be entered to control access to individual sequences, or to disable all keys except RUN, STOP and DISPLAY keys. Locking the keyboard in this way limits the operator to executing exactly the stored sequence, a valuable feature in a production-test environment.

The NVM contains in its system and sequence areas all the user-defined information in the instrument. This information or parts of it can be transferred over the HP-IB to and

from an external controller, so that the entire "character" of the instrument can be saved, restored, or copied.

Having both scratchpad and sequence areas gives the user several ways of working. Pressing a MEASUREMENT key or extracting a measurement from a sequence creates a record in the scratchpad that the user can modify and/or run on its own without affecting the contents of the sequence. New measurements can be added to the end of the sequence and measurements already in the sequence can be extracted, modified and replaced in the same order (Fig. 3).

Measurement Routines

The 3779A/B makes measurements on voice frequency, signaling, and first-order PCM signals. Most of the measurements need only a little processor bandwidth, so it was possible to write them in a slow, interpretive high-level language. They had to be read and understood by hardware designers and test engineers, so legibility was useful at the writing stage. It was also helpful to have the complex measurement hardware interactions amenable to debugging by means of the software trace embedded in the interpreter.

The quantizing distortion measurement described on page 7 under "Faster Results with Automatic Measurements" shows what a typical measurement routine does. Each pass through the routine represents a single measurement point, while the run-time system processes loops for point repetition, parameter sweeps and channel sweeps. When a sequence is run (Fig. 4), measurement records are brought from the sequence area to the scratch pad one by one as required.

Each type of measurement, for example GAIN, can run in up to four modes (A-A, A-D, D-A and E-E). The routines for different modes share as many subroutines as possible, and in fact A-A and E-E routines are combined since A-A measurements are made up of transmitter and receiver operations that can be viewed separately even though they are carried out in one instrument.

In A-D measurements, an analog stimulus is applied to a channel bank and the received signal is a stream of PCM words at frame rate, i.e., one every 125 μ s. The 3779A/B processor calculates the power represented by these words in real time. Although this is a high-bandwidth task, writ-

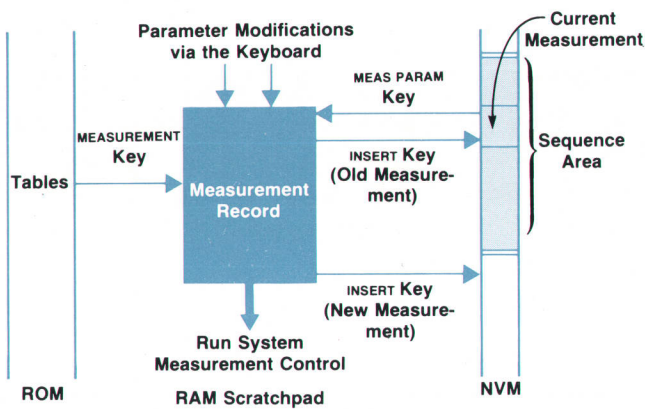

Fig. 3. The keyboard can be used to select, modify, and run measurements either from the sequence area or fresh from the tables. New measurements may be added to the sequence or existing ones modified.

ten in assembly language with attention to execution times and interrupt handling, the software implementation saves hardware in the digital receiver and allows the measurement algorithms to be adaptive. Some D-A measurements are made using tones at a submultiple of the PCM sampling frequency. These measurements use the processor in real time, generating a pattern of PCM words that is synchronous with the frame structure of the digital signal.

Submultiple frequency digital tones must be synchronous, otherwise phase beating occurs and results are not repeatable. The programming problem here is that the main analog receiver routines cannot accommodate the simultaneous generation of a PCM word every $125 \mu\text{s}$. Accordingly, a dedicated analog receiver routine is used, written in the form of an assembly language loop. It generates a PCM word every frame. The processor can generate flexible digital output signals to test the framing, error, and alarm logic of the receive sections of channel banks. These capabilities would be difficult to match in hardware.

Analog Receiver Routines

At the heart of the measurements are the receiver routines. These have a software resolution of 0.0025 dB. The main analog receiver routine is drawn in Fig. 5. Its first job is to have the input signal amplified to the level required by the receiver, without overloading. This in itself is a substantial task, since the instrument has to cope with badly asymmetric signals and face either polarity of a dc signaling voltage of up to 56V across its input. Higher and lower positive and negative threshold detectors show whether or not the signal has settled symmetrically and whether it is the right level. With the kind of time constants involved, the routine has to wait up to 7.5 seconds for asymmetry to disappear to be able to accommodate twice 56V. If symmetrical settling takes place within this time, the routine proceeds immediately. Otherwise, it assumes the signal itself is asymmetric and downranges if necessary. Once the receiver filter has settled to some extent, the secondary autorange operates on its output, and after a further delay for the final settling of filter and detector, the counter is read.

Digital Receiver Routines

Readings of digital level are made in real time by the

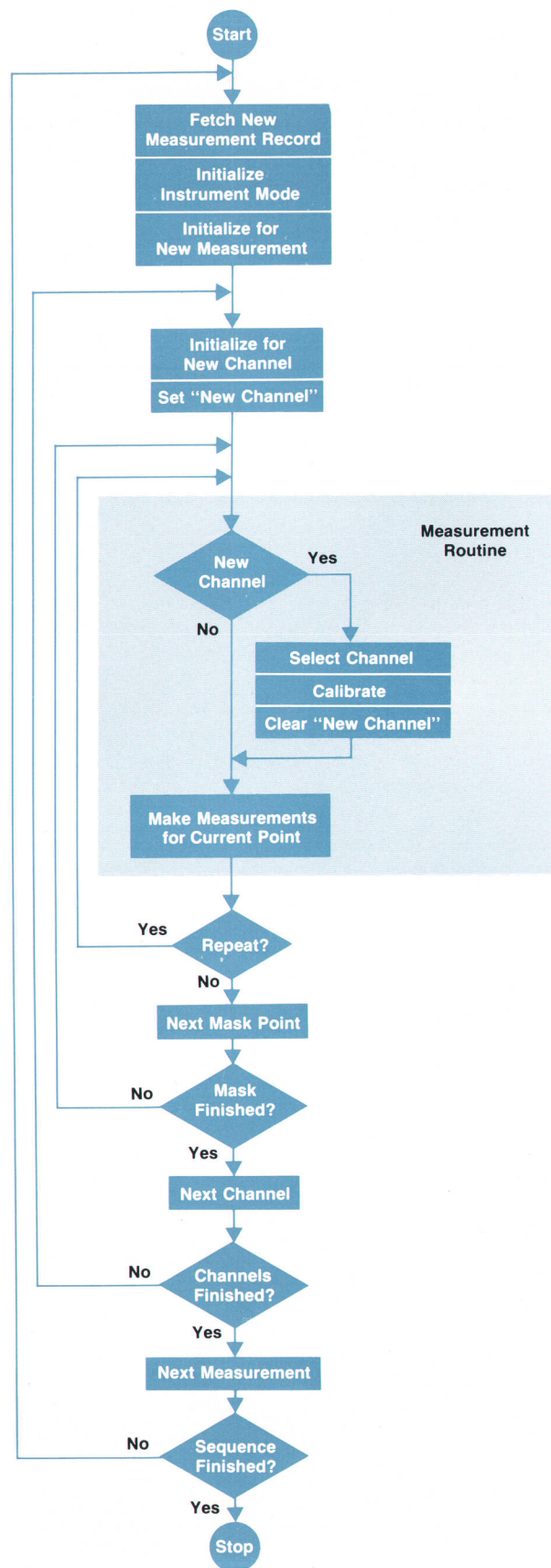

Fig. 4. The measurement routine executes once for each measurement point. It is enclosed by four program loops.

Software Development

At the time the HP SOS MC² was chosen as the processor for the 3779A/B, no software development tools existed that would run on the lab computer system at Hewlett-Packard Ltd. in Scotland, where the instrument was designed. Starting from scratch, therefore, we developed our own home-grown support tools that included features designed to ease software development.

A large program must be generated in blocks so that changes can be made with a minimum of rework. This is true during development, where a 1K word reassembly is feasible (5 minutes) but a 34K word one is not, and in production where the number of ROMs affected by a change must be kept down. The need is most simply met by generating absolute code, provided there is a sound method of linking blocks together. Linkage is one of the processes supported by a file substitution facility, transferring to and from different source files during assembly or compilation. Source files containing entry point declarations exist for each block; the entry point files for all externals referenced by a block are attached to it as it is assembled or compiled.

File substitution is a powerful tool. It also allows different versions of software to share files containing common sections, thereby avoiding duplication and problems in making software changes (a shared routine needs to be changed only once without having to remember every place that uses it).

Large programs present another problem in the enormous number of names to be handled by the support software: variable names, procedure names, and named constants. It is much better to name obscure bit patterns for switch settings, for example, and then refer to them by symbols so that programs are legible and easy to change. Support software that restricts naming is a nuisance; a 1000-name capability is not overkill.

The 3779A/B source program includes tables, assembly language, and high-level language. The importance of data structures in instrument control programs is not always recognized in currently available software development tools, but our assembler (which is written in Algol) includes powerful table generation features. For a high-level language, we substantially modified an existing compiler. The STAB-1 language developed at Strathclyde University, Glasgow, Scotland, is in the Algol/Pascal family; it generates virtual machine code for interpretation by the target processor. Our modifications oriented the language towards the application (new standard func-

tions), towards the target processor (new byte/digit operations, optimized 16-bit instructions) and towards a microprocessor environment for which we added flexible mapping of pointers and code, improved linking, calls with parameter passing to and from machine code routines, in-line machine code instructions, and treatment of I/O ports as ordinary variables in the source program. Despite shortcomings, the resulting language was adequate for the task.

Software development took place on an HP 2100 disc-based system (DOS III), the final product being absolute paper tapes that were either read into RAM boards in the prototype instrument, or later burned into EPROMs. For a hardware development aid, we were again compelled to go our own way, building a hardware breakpoint/step machine sitting on the processor bus and able to take complete control of it. Our debug aid had extra memory space for utility programs, a tape-reader interface, and a built-in 16-bit wide EPROM programmer.

In the instrument itself, there is a trace embedded in the interpreter loop for debugging STAB programs, with run-time program error checking, breakpoint/step facilities and access to utility programs. Finally, there are diagnostics built into the main analog receiver routine and the end-to-end communication routines that show on the instrument display the levels measured or the messages conveyed. These are invaluable aids to real-time debugging and fault-finding. Access to the trace, the utilities and the diagnostics is controlled by a switch inside the 3779A/B.

The use of the STAB language improved development productivity because, line for line, it generates more code than assembly language and it is easier to maintain. Leaving aside the service package, the table below shows the makeup of the source. During the software development, productivity was over 40 lines per man-day.

Source type	Source lines	Object words	Words/line
Data tables	4092	5937	1.5
Assembly language	20165	16059	0.8
STAB	6000	13015	2.2
TOTAL	30257	35011	

processor as described above. There is no time in software for digital filtering of the samples, so the results are essentially broadband. Some measurement routines use the peak positive and negative PCM codes observed in 800 samples, which give only a coarse measure of level but usefully show up offsets in the PCM encoder. However, most high-level A-D measurements use the rms routine that measures the rms voltage by squaring and summing the received samples to obtain a measure of the total received power (ac+dc), and measures the average voltages by summing without squaring, which yields the dc values. Thus, a simple calculation can find the rms value resulting from the ac components alone. The number of samples taken is 800, increasing for lower levels to 4000. Low-level digital signals are passed through a limited-range expanding D-A converter to be measured in the analog receiver.

Run-Time Error Processing

If the level to be measured is too low for any one of the stages in the process to work properly, a flag is set causing a < (less than) sign to be displayed in front of the result.

However, some measurements, like the reference point of a GAIN V. FREQUENCY test, must be correctly made. In this case, a low level causes a run-time error to be flagged.

Errors during a run are processed in different classes. Some operator programming errors can only be detected at this stage. Some instrument failures are trapped in the measurement routines, and measurements can be prevented by bad operation of digital interfaces. For these three classes, the run is aborted and a message is displayed. In contrast, if a measurement routine cannot continue because the test channel fails—when a reference measurement cannot be made, for example—then a message is printed, the channel is skipped, and the run continues on the next channel.

The Self-Test Package

The 3779A/B is a complex instrument, made with many hundreds of integrated circuits and large numbers of other components. Processor control means that things happen rapidly inside, and that measurement circuits cannot be directly set up from the front panel. Fault detection and location under these circumstances might well be a night-

mare were it not for the built-in self-test and service aids, which take up fully one third of the software.

A vital part of testing a processor-based instrument is testing the processor itself. The 3779A/B processor is designed so that a basic minimum kernel can be verified and then used to test larger areas. The tests run when the instrument is turned on while a switch combination is set on the processor board; no keyboard/display operations are required.

It is easy to implement self-test on the measurement parts of the 3779A/B because it contains transmitter-receiver pairs that can be connected for back-to-back testing. There are relays to isolate and loop the analog, digital and signaling circuits, and extra signal paths for injecting the standard source at intervals along the looped analog path so that faults can be not only detected but also diagnosed.

After a simple counter check, the standard source can verify the voltage-to-frequency converter, first on its own, and then in conjunction with a detector. Progressively, the overall analog path can in this way be verified against its specification. The overall test can then be repeated using the synthesizer as the stimulus.

Once the basic path has been established, back-to-back testing can be made diagnostic. Provided that only one element in the signal path is altered at a time, faults can usually be attributed to the last change made.

The basic self-test routines switch in alternative signal paths and vary signal parameters, extending the area of circuitry covered as far as possible. The analog routine tests

the continuity and gain of all signal paths, measures the attenuators, filters, and amplifiers against the detector, and checks all signal generators against the standard source, assuming only the accuracy of the standard source and the flatness and linearity of the detector. The digital routine

Table I

Test routine	Switch setting at power-on	Normal power-on	Self-test menu	HP-IB command
μP chip	X			
Test ROM	•	•	X	•
Processor RAM	X	•	X	•
Main ROM	X	•	X	•
Display RAM	X	•	X	•
Display character generator	X			
Keyboard/interrupt	X			
Processor bus exerciser	X			
NVM (core) ²			X	
HP-IB/modem			X	
Basic analog		X	X	X
Diagnostic analog			X	X
Filter masks			X	X
Digital		X	X	X
Single channel interface ¹			X	
Signaling ¹			X	
Service aids			X	
Utilities			X	

NOTES

- 1. Requires external connections. • automatic
- 2. Initializes NVM contents on exit. X selectable

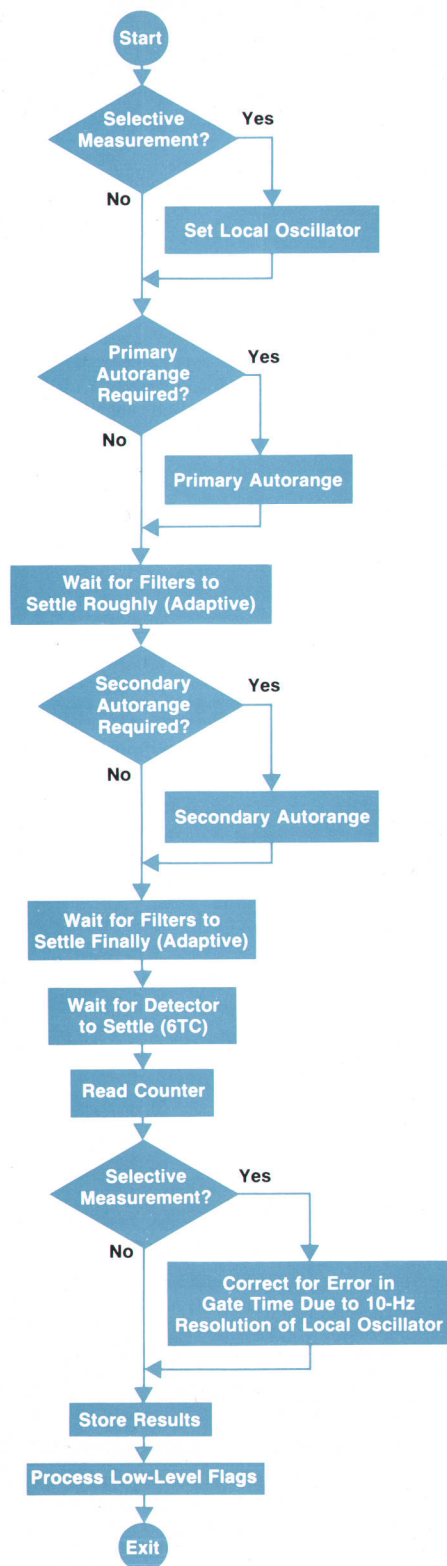

Fig. 5. Main analog receiver routine.

attempts to exercise all of the digital transmitter and receiver, but because they are more interconnected it is harder to locate faults.

These self-test routines can be run in various ways (see Table I). When the instrument is turned on normally, a minute is spent first on the processor, analog, and digital checks as an automatic confidence test. If a fault arises in the latter two routines, there is a temporary fault display, but the instrument returns to normal operation. This is to ensure recovery from a power failure in a remote unattended location.

The keyboard provides the main access to self test via a menu of routines. As a routine is run, many individual parameters are checked against limits. If there is a failure, the condition is held and diagnostic information is displayed. The other items on the menu are service aids for troubleshooting and adjustment in the form of many specific tests that can be run and repeated individually. Remote control of automatic self-test routines is provided via the HP-IB, so it is possible to diagnose an instrument at a distance, picking up failure information by requesting an ASCII dump of the display contents. HP-IB runs always include the processor basic checks to give confidence in the results.

The self-test package has been valuable in quality assurance and production testing, and in service support. It has made fault descriptions more specific, speeded up troubleshooting and kept the objective of component-level repair within the realm of possibility.

The HP-IB package

The 3779A/B uses the HP-IB in two ways. First, the HP-IB enhances the power of the instrument as a stand-alone measurement system with automatic channel selection and printing of results. Second, it allows the 3779A/B to be an intelligent part of a distributed surveillance or production test system. Thus, it is capable of controlling its own subsystem consisting of printer/scanner(s), or operating under computer control.

The HP-IB addresses of the 3779A/B and all devices forming its subsystem, together with the address of the system controller, are defined by entries in the HP-IB CONFIGURATION display. This display is accessed by pressing the HP-IB ADDR/LOCAL key while the 3779A/B is not under remote control.

In a system containing a controller other than the 3779A/B, the function of controlling the printer/scanner(s) may be handled by either the 3779A/B or the other controller (computer). The assignment of the controller-in-charge role then depends on the setting of the "take control" bits in the HP-IB CONFIGURATION display.

Whenever the 3779A/B wants to use the bus in order to set channels or print results, it will first detect the presence of another controller in the system by sensing the state of the HP-IB remote enable (REN) line. It assumes the presence of another controller when REN is true (low). In this case, the service request line (SRQ) will be driven true by the 3779A/B and on serial poll from the system controller, the 3779A/B will either ask for controller-in-charge status, if the corresponding "take control" bit is set, or otherwise inform the controller of the task required and execute it under comput-

er control.

Alternatively, if the REN line is false (high), the 3779A/B will assume the system controller role, execute HP-IB operation, and relinquish system controller status on completion. However, the number of tasks it can accomplish while system controller is limited to those programmed in its internal ROMs. To extend its measurement and system capability, it can be placed under computer control. Some possible examples are:

- Different scanner configurations can be programmed.
- Measurement results can be processed statistically, displayed in a graphical format, and so on.
- Additional measurement sequences can be stored by the system controller and distributed to other 3779A/Bs in the system.

- The 3779A/B may be run under remote control.

The 3779A/B bus commands can be divided into three groups:

- Display select codes; used to select a specific display.
- Dump codes; to dump display, parameter, or system data on to the bus. Parameter or system data may be stored and subsequently reloaded in any 3779A/B.
- Execute codes; these initiate a specific action such as run, stop, functional test, etc.

Since the number of individual parameters in the 3779A/B is extremely large, a cursor based solution has been used to program it from the front panel. Consequently, the group of parameters corresponding to a measurement, system description, or HP-IB configuration form the basic programming entity for remote control of the 3779A/B. Also, to increase the level of confidence in a remotely controlled 3779A/B, a handshake to each command using positive ACKnowledge in addition to the usual error flagging has been employed.

Acknowledgments

Virgil Marton gave enormous assistance in the overall definition of the software, and wrote much of the operating system, in particular the communications packages. Rob Pearson and Peter Scott wrote the real-time digital measurements, while Andrew Batham and Mike Bryant contributed to self test. Early ideas were contributed by Ralph Hodgson, Alastair Sharp, Robert Duncan and Rod May.

Vector Impedance Analysis to 1000 MHz

This new impedance analyzer measures fourteen impedance parameters of two-terminal components. It's fast, stable, accurate, and wide-range.

by Toshio Ichino, Hideo Ohkawara, and Noriyuki Sugihara

RADIO FREQUENCY impedance measurements, traditionally made with manually balanced impedance bridges, have more recently been made with analog vector impedance meters, Q meters, and network analyzers. These have not always been satisfactory because of accuracy or dynamic range limitations. We wanted to develop an RF impedance meter that overcame the deficiencies of conventional impedance meters and could be used as a system component covering the HF to UHF measurement frequency range (1 MHz to 1000 MHz). The result, Model 4191A RF Impedance Analyzer (Fig. 1), is an instrument that is unparalleled in measurement speed, accuracy and impedance measurement range.

This new analyzer's capabilities depend heavily on its powerful microprocessor and arithmetic/logic unit. Measured data is digitally corrected according to stored calibration data and the corrected data is converted to the selected parameters and displayed. This built-in processing power makes it possible to maintain a friendly user interface while meeting today's exacting customer requirements. The analyzer can serve a wide variety of customer needs, including semiconductor and electronic component evaluation, materials testing, and communications-related component measurement.

Probably the key feature of the 4191A is that it is not a

conventional impedance meter that measures only impedance. It can display any form of impedance including inductance, capacitance, resistance, reactance, conductance, dissipation factor, and so on. Its measurable-impedance range is 1 milliohm to 100,000 ohms in impedance or 1 microsiemens to 50 siemens in admittance, wide enough for most applications.

Measured parameters can be displayed as $|Z|$, $|Y|$, θ , R, X, G, B, L, or C. Any measured parameter can also be displayed as a percent deviation from a reference set on the front panel or programmed over the HP Interface Bus (HP-IB).^{*} As in conventional LCR meters, series or parallel equivalent circuit selection is provided. This wide selection allows the user to choose the most suitable measurement for the particular device under test.

A second major feature is the analyzer's accurate frequency settability. A frequency synthesizer generates the test signal, which remains phase-locked to an internal quartz reference oscillator. The frequency of the test signal can be varied in 100-Hz steps from 1 MHz to 1000 MHz. The 100-Hz test frequency resolution is useful for measurements on high-Q devices such as quartz crystals. Frequency start, stop, step, and auto or manual sweep controls facili-

^{*}Compatible with ANSI/IEEE 488-1978.

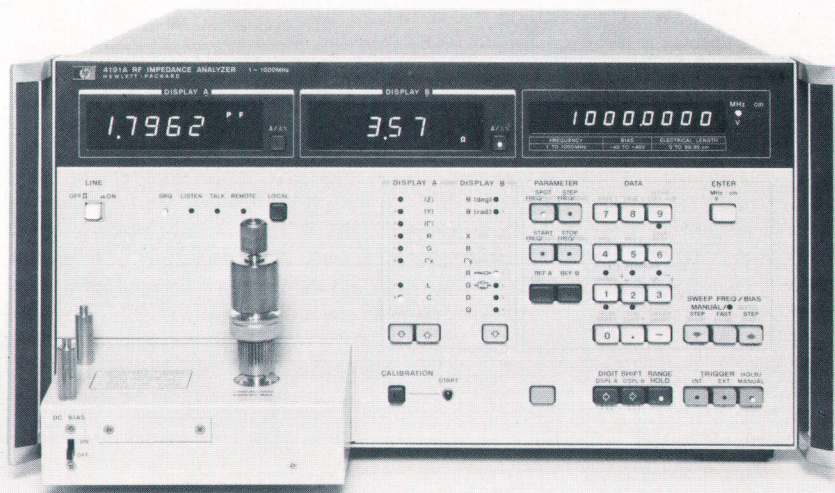
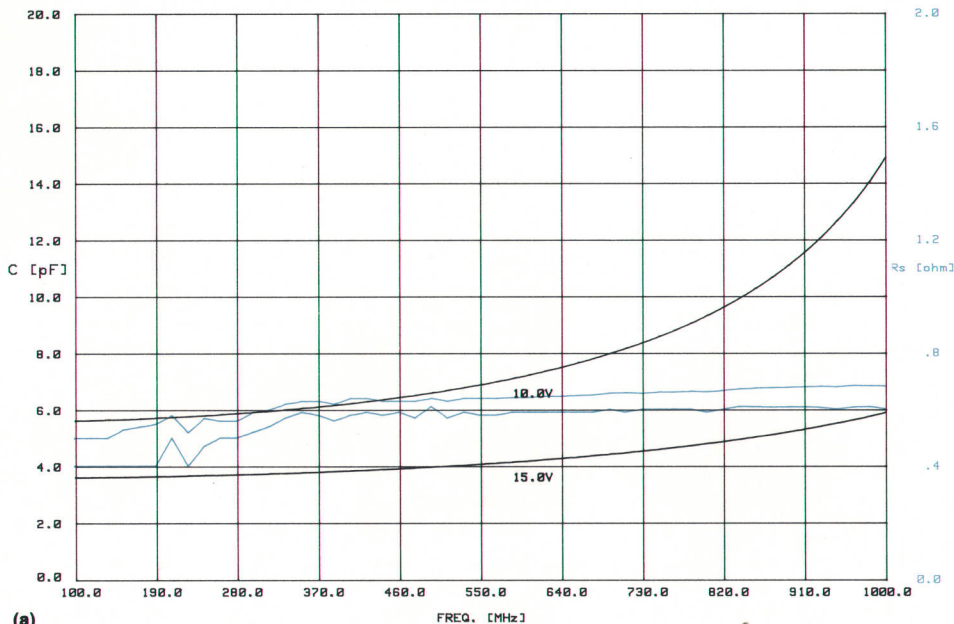
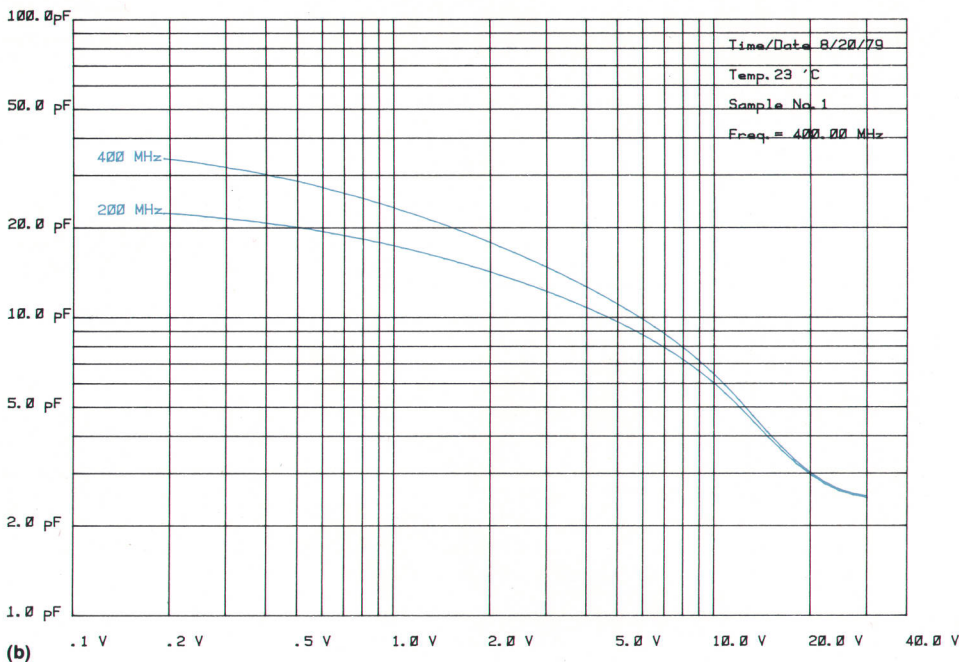

Fig. 1. Model 4191 RF Impedance Analyzer measures impedances from 1 m Ω to 100 k Ω at frequencies from 1 to 1000 MHz. Measurements are accurate within 0.5% to 2% of reading. The analyzer has frequency sweep capability, 4½-digit resolution, built-in dc bias with sweep capability, high stability, and a selection of versatile test fixtures.

4191A VVC C-F & R-F CHARACTERISTIC (16091A)



(a)



(b)

Fig. 2. (a) Capacitance and resistance of a varactor diode as functions of frequency, measured with the 4191A Impedance Analyzer at two different bias voltages. (b) C-V characteristics of the varactor diode at two test frequencies.

tate the measurement of component characteristics.

A sweepable dc bias voltage, controllable in 10-millivolt steps to ± 40.00 volts, is also included. This feature permits a very accurate plot of semiconductor characteristics (C-V plot).

HP-IB capability is standard and is useful in quality assurance tests or automated testing. All front-panel settings are remotely programmable and the measured data can be transmitted over the bus for calculation or manipulation. This feature contributes to lowering the cost of measurement and saving measurement time. With a desktop computer on the HP-IB, complex measurement control, statistical data analysis, and production of graphic plots of the measured data are possible.

A built-in backup memory memorizes all the calibration

data for error correction and all the measurement settings. This is an important convenience for making measurements that are repeated daily. The analyzer can store up to two independent measurement setups. A memorized front-panel setup, including frequency and bias, can be recalled instantly by pressing the recall key.

In UHF impedance measurements, test fixture design is very important. Model 4191A offers a precision coax test fixture, a convenient spring-clip fixture for holding chip components, and a conventional Q-meter/R-X meter binding-post fixture. Transistor impedance measurements can also be done with a network analyzer fixture by extending the DUT port with an air line. For circuit probing, a needle-tip probe is available.

The optional analog output offers an inexpensive way to

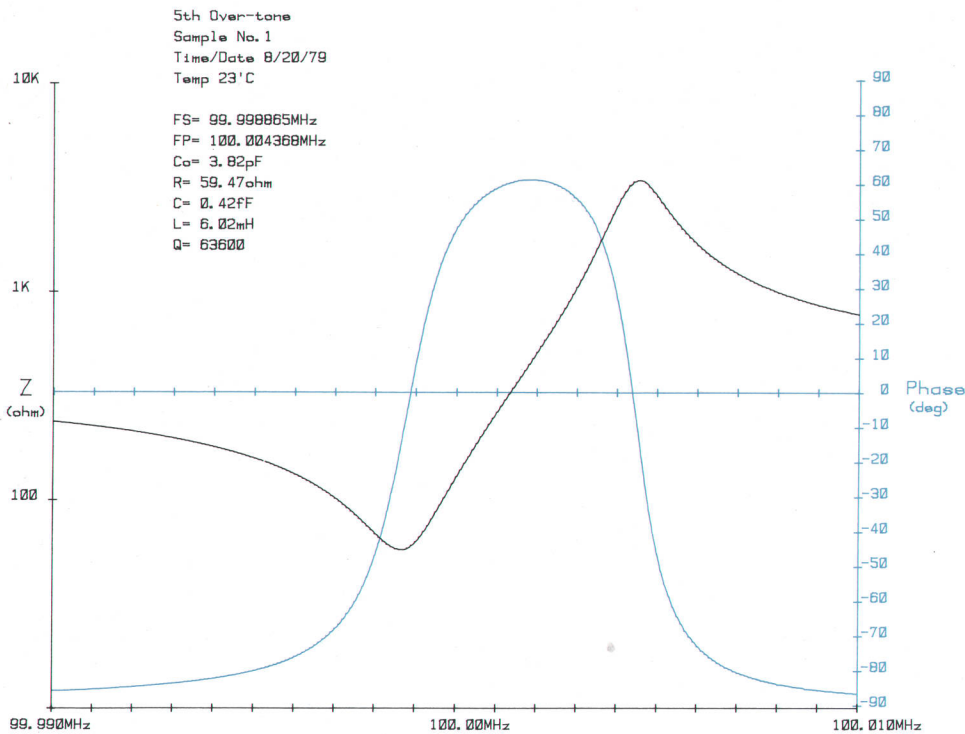

Fig. 3. $|Z|$ - Θ characteristics of a 100-MHz fifth-overtone quartz crystal.

make a permanent record of measured data. This option provides dc output voltages proportional to the displayed data. The swept bias or swept frequency capabilities can be used with this option to plot the bias or frequency characteristics of a component. Figs. 2, 3, and 4 are examples of typical measurement results.

Gamma Measurement

The basic measurement performed by the 4191A RF Im-

pedance Analyzer is a reflection coefficient measurement. The analyzer measures the vector ratio of the incident wave (from the measurement port to the device under test) to the reflected wave (from the device under test to the measurement port). The concept and principle are the same as for a port reflection coefficient (s_{11} or s_{22}) measurement made by a network analyzer. Knowing the reflection coefficient Γ , the impedance of the device under test (DUT) can be found as follows:

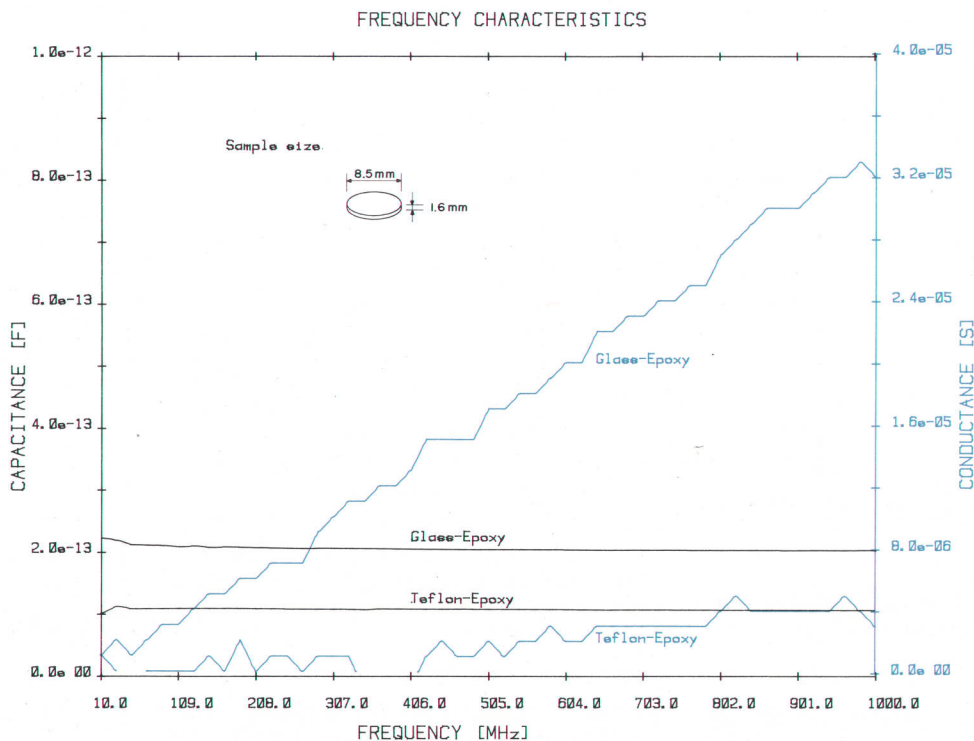

Fig. 4. C-G measurements on glass-epoxy and teflon-epoxy printed circuit boards. The conductance curve shows that the glass-epoxy board becomes lossy at high frequencies.

Error Correction in the Impedance Analyzer

Systematic errors in the 4191A RF Impedance Analyzer can be measured by calibrating the analyzer using the short, open, and 50Ω standards that are provided. Once these errors have been measured and stored, the analyzer automatically corrects measurements made on unknown devices under test (DUTs).

If we write Γ for the true reflection coefficient of the DUT and Γ_m for the measured reflection coefficient of the DUT, then:

$$\Gamma_m = e_{00} + \frac{e_{01} \Gamma}{1 - e_{11} \Gamma} \quad (1)$$

where e_{00} , e_{01} and e_{11} are, respectively, the directivity, tracking, and mismatch errors of the receiver section.

If we write Γ_{short} for Γ_m of the short standard, Γ_{open} for Γ_m of the open standard, and Γ_0 for Γ_m of the 50Ω standard, then:

$$\Gamma_{\text{short}} = \Gamma_m (\Gamma = -1) = e_{00} - \frac{e_{01}}{1 + e_{11}} \quad (2)$$

$$\Gamma_{\text{open}} = \Gamma_m (\Gamma = A) = e_{00} + \frac{e_{01} A}{1 - e_{11} A} \quad (3)$$

$$\Gamma_0 = \Gamma_m (\Gamma = 0) = e_{00} \quad (4)$$

where A is the reflection coefficient of the open standard. The open standard is a shielded open termination, and its capacitance value is derived theoretically. There are three unknown factors in equation 1, and we have three equations (2, 3, and 4), so we can solve for equation 1:

$$\Gamma = \frac{\bar{\Gamma}_m (\bar{\Gamma}_{\text{short}} - \bar{\Gamma}_{\text{open}}) A}{\bar{\Gamma}_{\text{short}} \cdot \bar{\Gamma}_{\text{open}} (1 + A) - \bar{\Gamma}_m (\bar{\Gamma}_{\text{open}} + A \bar{\Gamma}_{\text{short}})} \quad (5)$$

Where $\bar{\Gamma}_m$, $\bar{\Gamma}_{\text{short}}$, and $\bar{\Gamma}_{\text{open}}$ are, respectively, $\Gamma_m - \Gamma_0$, $\Gamma_{\text{short}} - \Gamma_0$, and $\Gamma_{\text{open}} - \Gamma_0$.

The 4191A solves equation 5 to derive the true reflection coefficient of the DUT, then converts this value to the required parameters for display.

$$Z = \frac{1 + \Gamma}{1 - \Gamma} \times 50 \text{ (ohms)}$$

The selection of reflection coefficient as the basic measurement mode provides the following advantages:

1. Easy remote control. A measurement is done and the data processed digitally. There is no need to tune a variable air capacitor.
2. Extension of the DUT port with 50-ohm transmission line is possible.
3. Traceable impedance standards (0Ω 50Ω, 0S) can be used for system calibration.

On the other hand, the measured DUT is not always close to 50 ohms. Generally speaking, measurement accuracy is poor for purely reactive components or those close to 0Ω and 0S (short and open circuits).

To narrow the gap between its theoretical limits and its

Open Capacitance

The open end of a coaxial line should look like an ideal open circuit, but actually it can be shown that the line is terminated in a capacitive admittance because of the effect of fringe fields and radiation.

The 4191A's open-circuit standard is an open termination cap or shielded open. It is a short cylinder that mates with the test port connector, and its discontinuity capacitance is approximately 0.082 pF. The reflection coefficient of this capacitance is the factor A used in the error correction equation (5).

Calibration Data Interpolation

During calibration, the 4191A divides the frequency range entered by the user into 50 equal or logarithmic intervals. The instrument takes calibration data at 51 points and stores it in its memory.

When the measurement frequency does not coincide with one of the calibration points, the 4191A interpolates between calibration points and carries out the error correction process. Since the simplest interpolation, a linear approximation, often produces considerable error, a cubic interpolation is done using a Lagrange interpolation formula. A cubic curve that passes through four calibration points, two before the measurement frequency and two after the measurement frequency, is generated. The value of this curve at the measurement frequency is the value used for error correction.

Electrical Length Compensation

When a DUT is mounted at the end of a 50Ω transmission line that is extended from the reference plane of the 4191A, the incident wave travels through the extended line from the test port to the DUT. The reflected wave travels through the line from the DUT to the test port. Assuming that the extended transmission line is a good 50Ω lossless line, the reflection coefficient measured at the reference plane differs in phase by twice the electrical length of the line from the true DUT reflection coefficient. If the user enters the length of the line via the keyboard, the 4191A compensates for the phase shift of the extended line. The compensating equation is:

$$\Gamma = \Gamma_m e^{\frac{j2\omega l}{c}}$$

Where Γ_m is Γ at the reference plane, l is the length of the extension, and c is the velocity of light.

actual performance, the 4191A had to be carefully designed. To maintain a wide measurement range and acceptable accuracy, severe requirements had to be placed on the test signal residual noise and the signal-to-noise ratio and accuracy of the RF-to-IF sampling frequency converter and receiver. To improve accuracy further, the measured data is error-corrected using prestored 0Ω, 50Ω, and 0S calibration data. In this way any residual error in the system is eliminated. From this accurate reflection coefficient measurement, further parameter conversion is done with stored programs. Thus impedance, admittance, capacitance, or inductance are easily determined.

RF Bridge

The major sections of the impedance analyzer are the RF bridge, the signal source, the receiver, and the digital sec-

tion.

The RF bridge is a directional bridge for measuring the reflection coefficient of the DUT (see Fig. 5). The test signal from the signal source section is fed to this section and divided into two halves by a power splitter. One of these signals, after attenuation and electrical length compensation, becomes the reference channel output signal to the receiver section.

The other signal from the power splitter is fed to the directional bridge after passing through a 6-dB attenuator/dc bias circuit. A balun transformer directs this signal into two channels. One goes to an internal standard 50-ohm resistor and the other goes to the DUT port. The voltage across the standard resistor and that across the DUT are combined to form the test channel output. When the DUT port is terminated in 50 ohms, the bridge is balanced and the test channel output is zero.

The test and reference channel outputs from the RF bridge go to the receiver section, where they are down-converted, synchronously detected, and processed by a dual-slope integrator to measure their vector ratio.

The key component of the RF bridge is the balun transformer (unbalanced-to-balanced transformation). It is wound with fine semirigid coaxial cable on a toroidal ferrite core. This construction maintains sufficient balance over the frequency range of 1 to 1000 MHz. The entire RF bridge section is temperature-controlled by a heater and a temperature control circuit.

Signal Source Section

The objective of the signal source is to deliver a 0-dBm RF signal to the RF bridge at frequencies from 1.0 to 1000.0 MHz. For high-resolution impedance measurements with good repeatability, the RF signal must be accurate, stable, and low-noise. Such a signal is generated by indirect synthesis using phase-locked loops and low-noise voltage controlled oscillators (VCOs).

The block diagram of the signal source section of the 4191A is shown in Fig. 6. The basic concept is to phase-lock the 250-to-500-MHz VCO #1 to a harmonic of a 100-kHz signal derived from a crystal oscillator and then convert the VCO output to a 1.0-to-1000.0-MHz signal by mixing, dividing, and doubling.

VCO #1, a high-speed divide-by-N counter, and a phase-locked loop are used to generate a 250.1-to-500.0-MHz signal with 100-kHz frequency resolution. The frequency range of VCO #1 is divided into nine frequency bands by switching inductors in the VCO tuning circuit under control of the logic section, so that a stable and low-noise signal can be generated. The division of the frequency range by switching inductors makes the VCO less sensitive to noise (tuning sensitivity is about 2 MHz/V) and improves phase-lock speed.

The divide-by-N counter, which is composed of a $\div 10/\div 11$ ECL prescaler and high-speed TTL programmable counters, converts the 250-to-500-MHz VCO signal to a 100-kHz pulse signal that is compared to the reference 100-kHz signal in the phase/frequency detector. The phase/frequency detector output is integrated to produce an error signal that tunes the VCO until phase lock is achieved.

The 250.1-to-500-MHz phase-locked signal with 100-kHz resolution is used to generate other frequencies in three ways. Test signals from 1.0 to 32.0 MHz are produced by tuning the phase-locked signal so the output of the first $\div 2$ circuit is between 201.0 and 232.0 MHz and mixing this signal with the 200-MHz local oscillator signal. Test signals from 32.1 to 250.0 MHz are obtained by selecting and filtering the appropriate output of the $\div 2$, $\div 4$, $\div 8$ ECL divider chain with the phase-locked signal tuned so that one of these three outputs is at the desired frequency. Eight selectable lumped low-pass filters are used to reduce harmonics from the dividers. Test signals from 500.2 to 1000.0 MHz are obtained by filtering the output of the doubler, which is a transistor full-wave rectifier. Varactor-tuned bandpass fil-

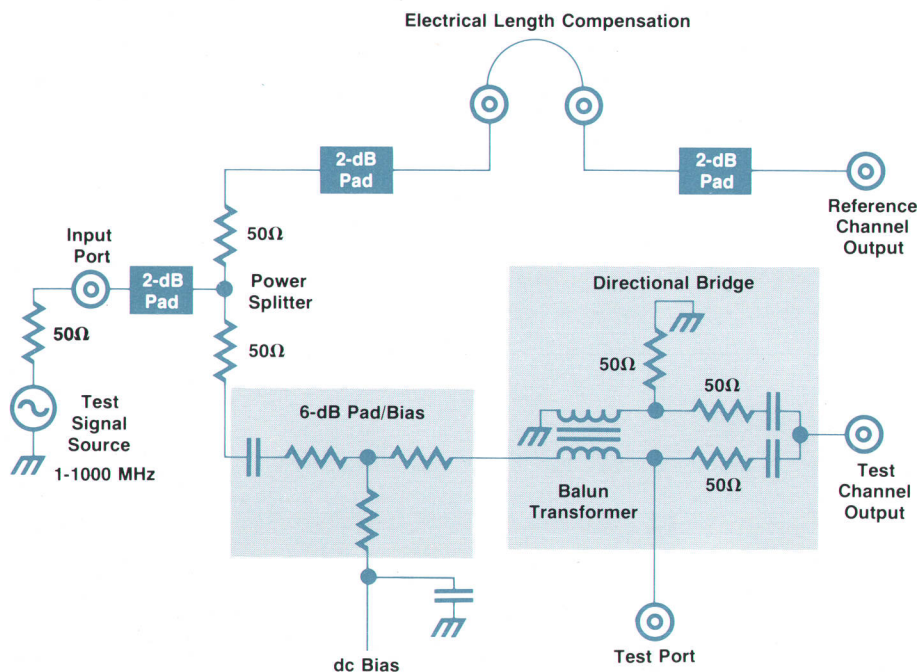

Fig. 5. RF bridge section of the 4191A Impedance Analyzer.

ters are used to reduce subharmonics caused by the doubler.

Leveling of the output signal is achieved by feeding back an ALC (automatic level control) signal to the PIN modulators in each frequency path. The ALC signal is an error voltage from the receiver section. Output power level at the test port is about $-20 \text{ dBm} \pm 1.5 \text{ dB}$ from 1.0 MHz to 1.0 GHz. Test port power level variations are mainly the result of cable losses in the RF bridge and the conversion loss of the sampler in the receiver section.

Frequency resolution of 100 Hz (Option 002) is obtained by adding two more lock loops, a low-frequency synthesizer loop and a summing loop. In 100-Hz frequency resolution operations, the 250-to-500-MHz VCO #1 is phase-locked to a harmonic of the 100-kHz reference to produce a signal between 249.1 and 499.0-MHz.

In the low-frequency synthesizer loop, the output signal of the 100-to-110-MHz VCO, which is phase-locked to a harmonic of a 10-kHz reference, is divided by 100 to generate a low-noise 1.0000-to-1.1000-MHz signal with 100-Hz frequency resolution. This signal is fed to the phase detector of a summing loop.

The 250-to-500-MHz VCO #2 is phase-locked such that the difference frequency of VCO #1 and VCO #2 is equal to the frequency of the low-frequency synthesizer loop, so the output frequency of VCO #2 is 250.1000-to-500.0000-MHz with 100-Hz frequency resolution.

The search generator, controlled by the frequency detector, is used to improve the phase-lock speed of the summing loop. It rapidly tunes VCO #2 towards the phase-lock frequency. When the VCO #2 frequency is near the lock frequency, the frequency detector stops the search generator and the loop is allowed to lock.

Receiver Section

A block diagram of the receiver section is shown in Fig. 7. The 1.0-to-1000.0-MHz RF signals from the RF bridge are down-converted to 100-kHz intermediate-frequency (IF) signals by a precision sampler and low-noise phase lock loop. The sampler acts like a harmonic mixer in a heterodyne frequency converter. After down-conversion the reference and test channel IF signals are synchronously detected and processed by the dual-slope integrator to measure their vector ratio.

The low-noise VCO, which covers a 60-to-90-MHz frequency range in five bands, drives the programmable divider, which divides the VCO frequency by a factor between 8 and 60. The 1.1-to-11.25-MHz square-wave signal from the programmable divider drives a step-recovery diode, which generates sampling pulses about 300 picoseconds wide.

Variations of the sampling efficiency of the samplers in both receiver channels are kept to a minimum by careful

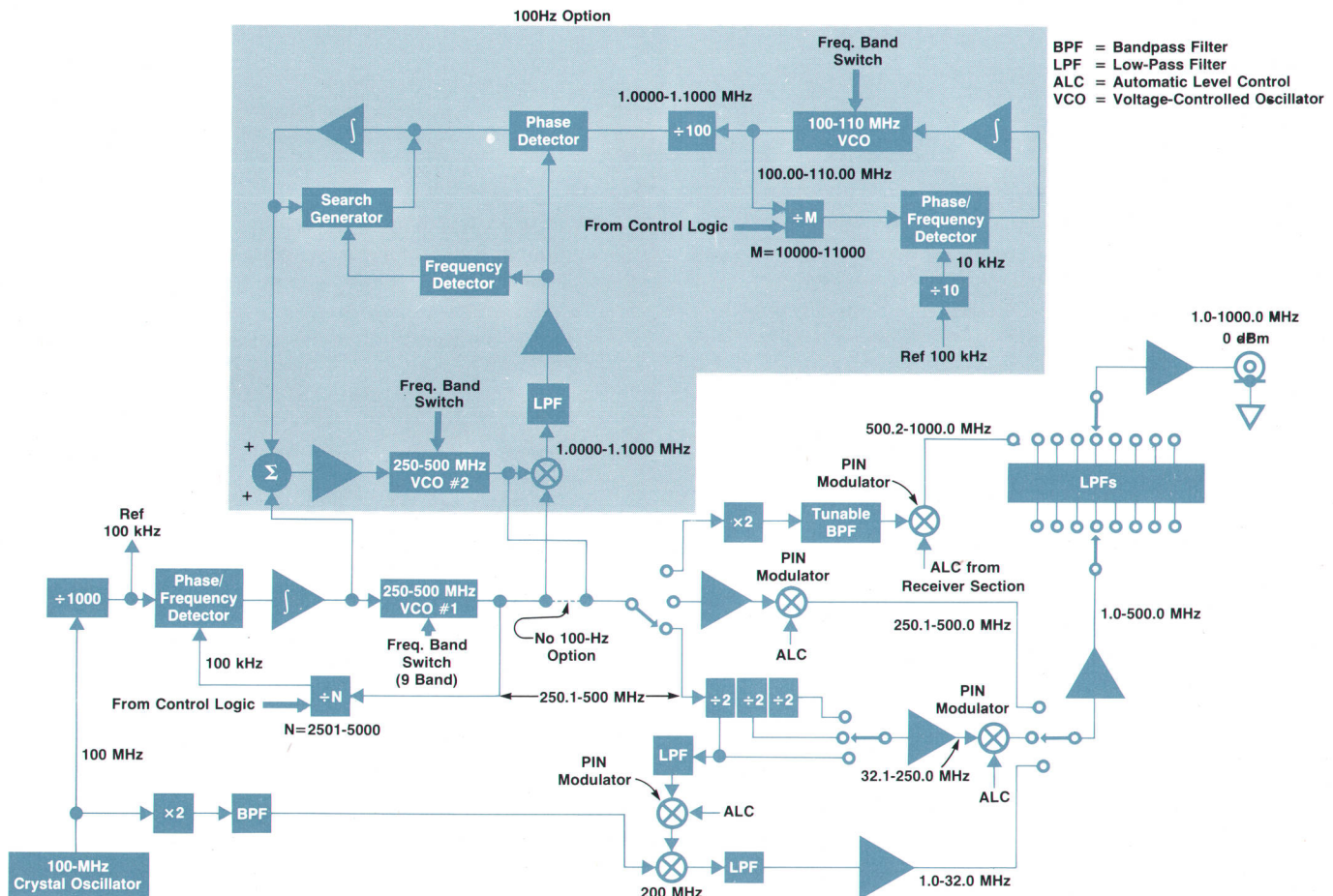

Fig. 6. 4191A signal source section. Test signal is generated by indirect synthesis using phase-locked loops and low-noise oscillators.

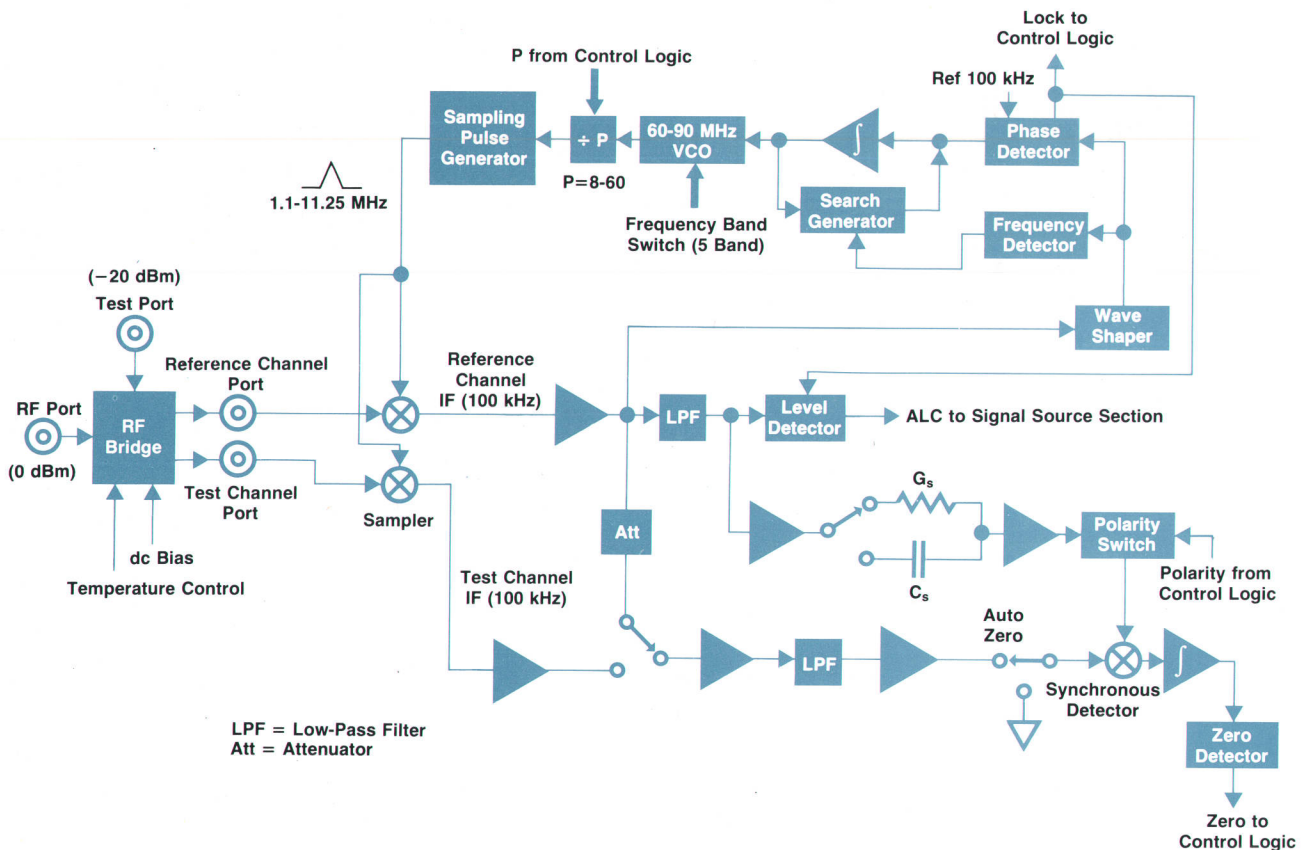

Fig. 7. 4191A receiver section down-converts and detects the test and reference signals from the RF bridge, and measures the vector ratio of these signals to determine the reflection coefficient of the device under test.

design of the samplers and the sampling pulse generator. An external signal source up to 2 GHz can be phase locked without degradation of the sampling efficiency.

When the RF test frequency is changed, the band of the 60-to-90-MHz VCO and the dividing factor P of the programmable divider are set to their proper conditions under control of the logic section. The search generator starts to sweep the 60-to-90-MHz VCO from high to low frequency. When the intermediate frequency is about 150 kHz, the frequency detector stops the search generator and the phase detector takes control of the 60-to-90-MHz VCO to establish phase lock.

An automatic level control (ALC) signal is generated by the level detector and sent to the signal source section to maintain a -20 -dBm output power level at the test port. Part of the reference IF signal, which is proportional to RF power, is full-wave rectified to a dc level in the level detector. The ALC signal is the amplified difference between this dc level and a reference dc level corresponding to -20 dBm at the test port.

The response of the ALC circuit is relatively slow compared with the search speed. Therefore, the ALC circuit is inactivated during search conditions. However, with no ALC signal applied to the PIN modulators in the signal source section, the RF power level at the RF bridge and the samplers could be excessive, causing the samplers to produce distorted IF signals that might result in false operation

of the frequency detector in the receiver section. To avoid this problem a dc voltage is applied to the PIN modulators when a search is in progress, keeping the RF power small, but sufficient for frequency detection. When the frequency detector stops the search generator, this dc voltage is disconnected and the ALC circuit is enabled again.

A portion of the reference IF signal is fed to the C_s - G_s circuit, where accurate 0° and 90° reference signals used for the synchronous detector are generated. The 0° and 90° components of the test signal and the 90° component of the reference signal are detected with respect to the 0° component of the reference signal. These four analog values are converted to digital signals by dual-slope integration and the vector ratio of the test signal and the reference signal is computed in the logic section.¹

Sampler

The 1-to-1000-MHz measurement signal is down-converted to a constant 100-kHz IF by the sampling frequency converter (see Fig. 8).

The test signal from the RF bridge is terminated by a 50-ohm terminator. This signal is then fed to a sampling gate consisting of four Schottky barrier diodes. This gate turns on when a sampling pulse approximately 300 picoseconds wide is applied to it. The sampled RF signal charges the hold capacitor and this voltage is held until the next sampling pulse occurs. The hold voltage is buffered by

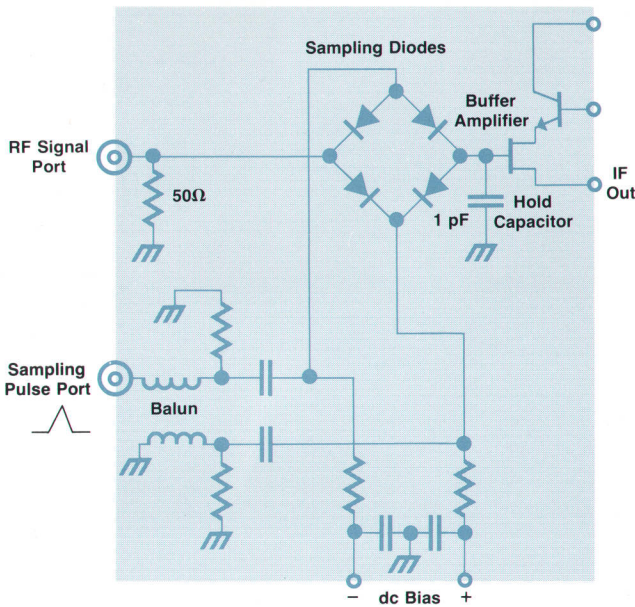
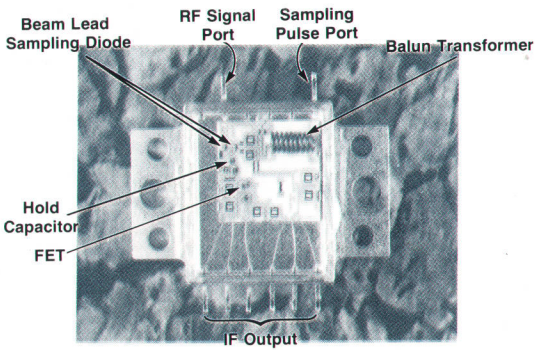

Fig. 8. Hybrid-integrated circuit sampler acts as a mixer to down-convert the 1-to-1000-MHz measurement signals.

an amplifier with high input impedance.

Since the sampler must have a flat frequency characteristic over the measurement frequency range, maintain low signal-to-noise ratio over a wide impedance measurement range, and be stable enough to provide sufficient accuracy, a thin-film hybrid circuit is used. For stable propagation delay between the sampling pulse port and the RF port, a

semirigid coaxial balun transformer is used instead of the conventional type balun (twisted pair wound around a ferrite core).

Digital Section

Fig. 9 shows the overall block diagram of the digital section. All data and analog controls are managed by an M6800 microprocessor. The control data to the analog circuits and the front panel is transmitted serially.

The battery memory back-up retains the error correction data and instrument settings when the line power is turned off.

Test Fixtures

Applications of the Model 4191A are extended by carefully designed test fixtures and accessories. Four different types of test fixtures are available for various measurement frequency ranges and accuracies. For circuit probing, a probe is available.

Model 4191A is calibrated at the DUT port by short, open, and 50Ω termination standards. These termination standards are furnished. The DUT port is the reference calibration plane for all measurements.

Before using a test fixture, one must enter the electrical length indicated on the fixture via the keyboard. The open admittance (stray capacitance) of the test fixture can then be measured before the DUT measurement, so that it can be offset by the microprocessor. This significantly improves measurement accuracy in high-impedance measurements. Similarly, the short-circuit impedance of the test fixture can be cancelled if the furnished shorting bar is used to make an offset measurement before the DUT measurement. This significantly improves accuracy in low-impedance measurements.

The 16091A (see Fig. 10) is a coaxial test fixture. It is a cavity type fixture so that any radiation error is minimized. To calibrate it, the calibration standard is mounted on the end surface of the APC-7 connector at the point where the DUT is connected. The low-potential end of the fixture (i.e., ground) is shorted by a shorting spring. This shorting spring slides along the inside wall of the cavity to minimize the short-circuit impedance. The cavity configuration minimizes measurement errors at frequencies up to 1000 MHz. To mount small DUTs in the fixture, gold-plated pins are attached to the DUT.

The 16092A (see Fig. 11) is a spring-clip type of fixture usable through 500 MHz. It is convenient for the measure-

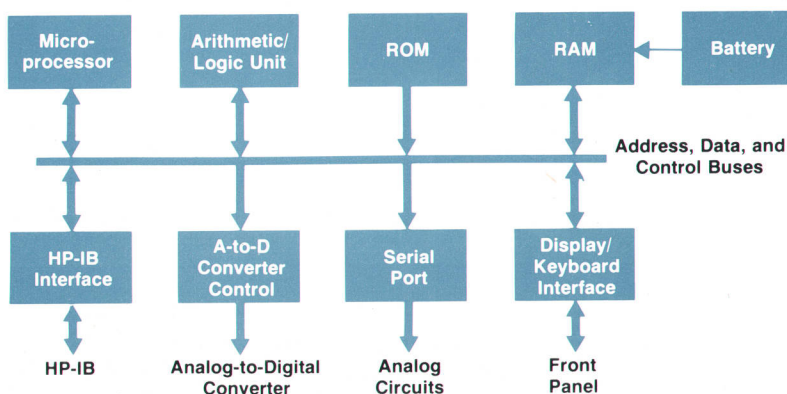

Fig. 9. 4191A digital section. An M6800 microprocessor manages all operations.

Parameter Conversion

The 4191A RF Impedance Analyzer fundamentally measures the reflection coefficient of the device under test (DUT) and then converts this measurement into other parameters, such as impedance, admittance, inductance and capacitance. The conversion equations may be summarized as follows ($Z_0 = 50$ ohms):

Impedance $50 \times \frac{1+\Gamma}{1-\Gamma} = R + jX$

$$\sqrt{R^2 + X^2} = |Z|$$

$$\tan^{-1} \frac{X}{R} = \arg Z = \theta$$

Admittance $0.02 \times \frac{1-\Gamma}{1+\Gamma} = G + jB$

$$\sqrt{G^2 + B^2} = |Y|$$

$$\tan^{-1} \frac{B}{G} = \arg Y = \theta$$

Inductance $\frac{X}{2\pi f} = L_s$

$$-\frac{1}{2\pi fB} = L_p$$

Capacitance $\frac{B}{2\pi f} = C_p$

$$-\frac{1}{2\pi fX} = C_s$$

Dissipation factor $\frac{R}{|X|} = D$

$$\frac{G}{|B|} = D$$

Quality factor $\frac{|X|}{R} = Q$

$$\frac{|B|}{G} = Q$$

The diagram shows series and parallel equivalent circuits for the DUT.

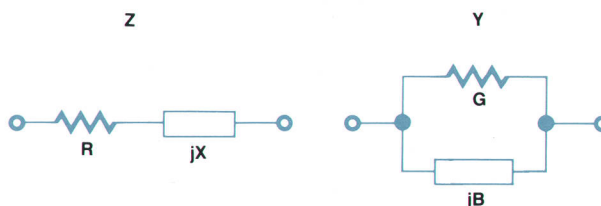

ment of small chip capacitors or axial-lead components. The DUT is mounted by pressing the spring, inserting the DUT, and releasing the spring. This fixture is particularly convenient when minimum dielectric loss in the insulator and low series loss are desirable.

The 16093A and 16093B (see Fig. 12) are conventional binding post test fixtures similar to those used with R-X and

Q meters. These are useful up to 250 MHz or 125 MHz, respectively.

The 16094A (see Fig. 13) is a probe fixture that is mounted at the tip of a precision coaxial cable. It is useful for measuring impedance in circuits up to 125 MHz.

The extension capability of the DUT port is another important feature of Model 4191A. Measurement of the

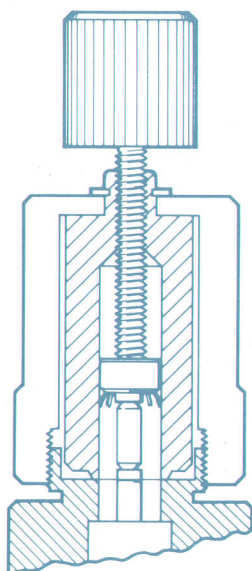

Vertical Section

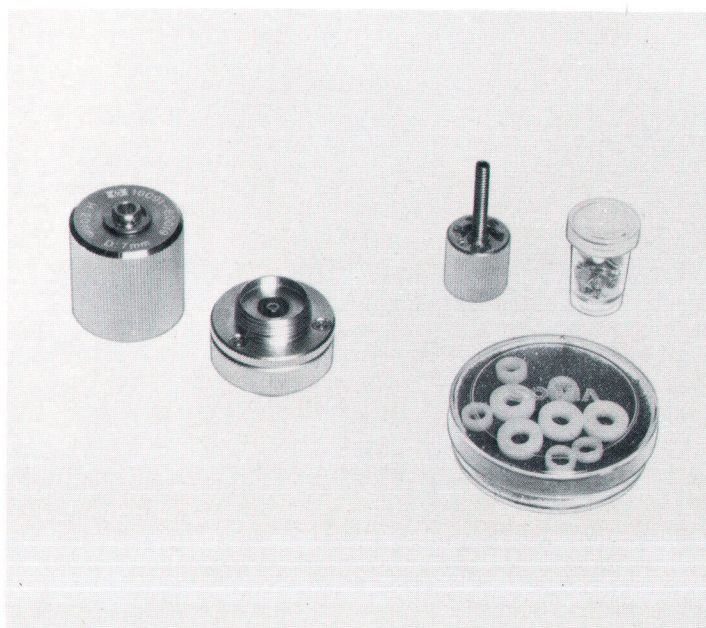
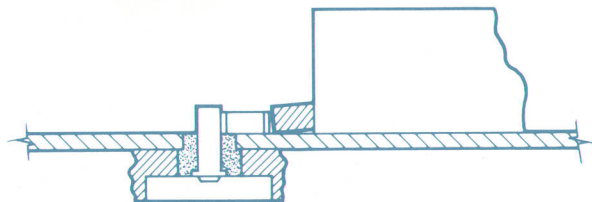
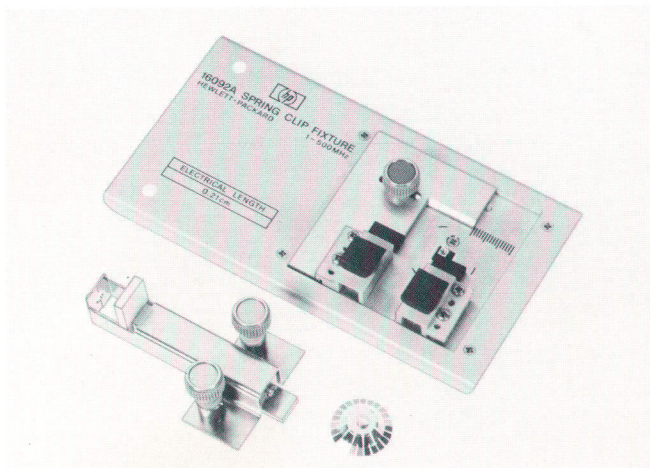

Fig. 10. 16091A coaxial fixture set consists of cavity-type fixtures useful up to 1000 MHz.



Vertical Section

Fig. 11. 16092A spring clip fixture is useful through 500 MHz for small chip capacitors or axial-lead components.

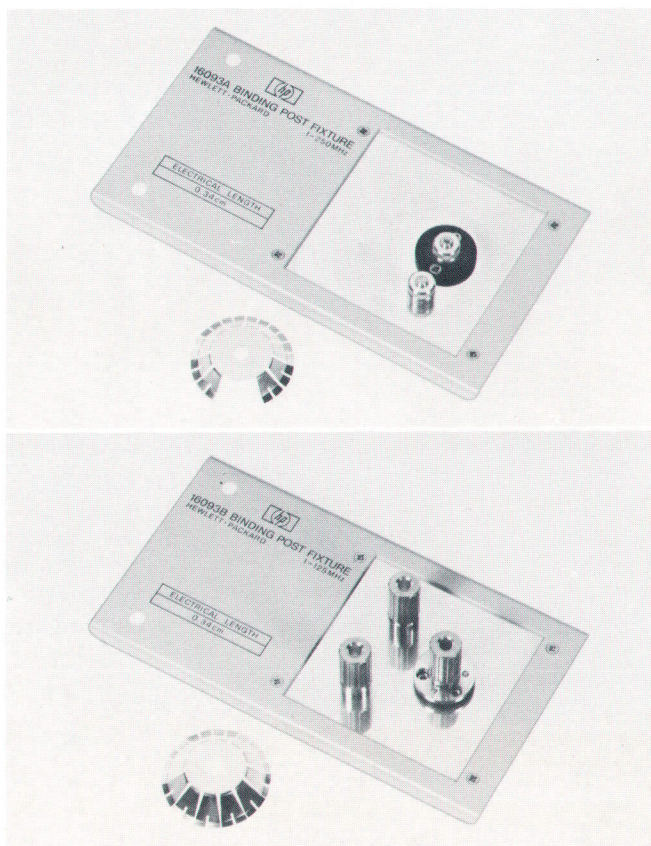

Fig. 12. 16093A and 16093B binding post fixtures are useful up to 250 MHz and 125 MHz, respectively.

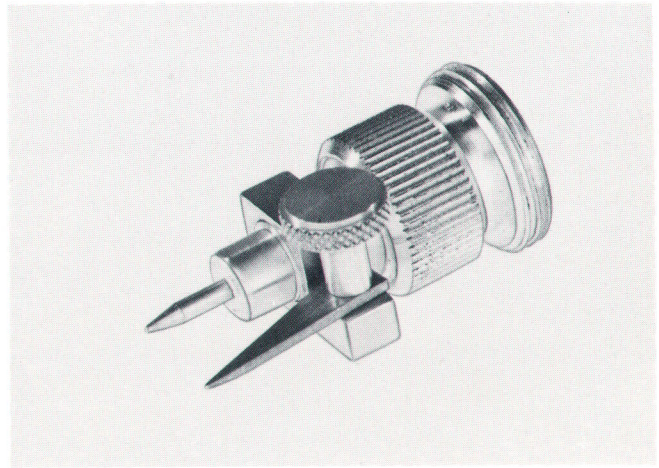
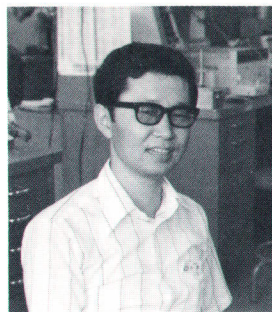

Fig. 13. 16094A probe fixture, mounted at the tip of a precision coaxial cable, is useful to 125 MHz.

Toshio Ichino



Toshio Ichino joined Yokogawa-Hewlett-Packard in 1970 just after receiving his BSEE from the University of Electrocommunications in Tokyo. He has worked on the 86222A/B Sweeper Plug-In and the 4273A 1-kHz Preset Capacitance Meter, and he designed the signal source section of the 4191A RF Impedance Analyzer. Toshio and his wife have a one-year-old daughter. He enjoys hiking, swimming and playing contract bridge in his spare time.

Noriyuki Sugihara



Noriyuki Sugihara, project leader for the 4191A RF Impedance Analyzer, joined Yokogawa-Hewlett-Packard in 1969 after receiving his BSEE degree from Waseda University. He transferred to HP's Stanford Park Division in 1972 and was involved in a portable microwave repeater project. During his stay in California, he received his MSEE degree from Stanford University. He is married and has a one-year-old daughter. He enjoys hiking and ham radio.

Hideo Ohkawara



Hideo Ohkawara was born in Sendai, Japan, and received his BSEE and MSEE degrees from Tohoku University in 1973 and 1975. He joined Yokogawa-Hewlett-Packard in 1975 and has been involved in 4191A development, doing transducer section design and performance analysis. He plays traditional Japanese musical instruments, the shamisen and the koto, and enjoys ice skating, swimming and camping.

SPECIFICATIONS

HP Model 4191A RF Impedance Analyzer

PARAMETERS MEASURED: $|Z|-\theta$, $|Y|-\theta$, $|\Gamma|$ (reflection coefficient)- θ , R-X, G-B, $\Gamma_x-\Gamma_y$ (rectangular coordinate display of Γ), L-R-G-D-Q, C-R-G-D-Q.
 DISPLAY: 4½-digit max., max. display 19999 count.

DEVIATION MEASUREMENT: Displays measured value deviation (Δ) from stored reference, or deviation in percent ($\Delta\%$) for all parameters.

MEASURING SIGNAL: Internal Synthesizer:
 FREQUENCY RANGE: 1 MHz to 1000 MHz
 FREQUENCY STEPS: 100 kHz (1 to 500 MHz), 200 kHz (500 to 1000 MHz)
 FREQUENCY ACCURACY: ± 3 ppm
 SIGNAL LEVEL (terminated with 50 Ω): -20 ± 3 dBm

MEASUREMENT MODE:
 SPOT MEASUREMENT: Measures specific frequency (or bias voltage).
 SWEEP MEASUREMENT: Linear sweep measurement or logarithmic sweep measurements.

AUTOCALIBRATION: Automatic error compensation referenced to connected termination.
 REFERENCE TERMINATIONS: 0 Ω , 50 Ω , 0S.
 CALIBRATION FREQUENCIES: 51 frequencies between start and stop frequencies.
 NOTE: Frequency error correction for other than calibration frequencies is automatically done by third-degree interpolation. Automatically compensates for open capacitance of 0.082 pF with 0S termination.

ELECTRICAL LENGTH COMPENSATION: Automatic compensation for electrical length 0 to 99.99cm.

DC BIAS: Internal dc Bias:
 VOLTAGE RANGE: $-40.00V$ to $+40.00V$, 10 mV steps.
 SETTING ACCURACY: $\pm(0.1\%$ of setting + 10 mV).

KEY STATUS MEMORY: Measurement conditions set by front panel keys can be stored and recalled.

MEASURING TERMINAL: APC-7 connector.
HP-IB DATA OUTPUT AND REMOTE CONTROL: Furnished.

MEASURING RESOLUTION AND ACCURACY:
 Γ MEASUREMENT:
 $|\Gamma|, \Gamma_x, \Gamma_y$ ACCURACIES: $0.0035 + 0.00001f$

$|\Gamma|, \Gamma_x, \Gamma_y$ RESOLUTION: 0.0001
 $|\Gamma|, \Gamma_x, \Gamma_y$ TYPICAL ACCURACIES: $0.0011 + 0.0000047f$
 θ ACCURACY: $(0.0035 + 0.00001f)/|\Gamma|$ (rad.)
 θ MAX. RESOLUTION: 0.01°
 where f = measuring frequency in MHz
 MEASURING TIME: < 800 ms. < 250 ms in High-Speed Mode.
 SIGNAL SETTLING TIME (when frequency is changed): ≤ 200 ms.

General Information

OPERATING TEMPERATURE: 0 to 55°C, Relative Humidity: $< 95\%$ at 40°C.
POWER: 100, 120, 220V $\pm 10\%$, 240V $\pm 10\%$ -5% , 48 to 66 Hz.
POWER CONSUMPTION: 150VA max.
DIMENSIONS: Approx. 425.5 mm W \times 230 mm H \times 574 mm D.
WEIGHT: Approx. 24 kg (standard model).
ACCESSORY FURNISHED: Accessory Case (with Reference Terminations 0 Ω , 50 Ω and 0S).

OPTIONS
 OPTION 002: Internal Synthesizer in 100/200 Hz steps.
 OPTION 004: Recorder Output.

ACCESSORIES AVAILABLE:
 16091A COAXIAL FIXTURE SET: Measuring frequency: 1 MHz to 1000 MHz.
 16092A SPRING CLIP FIXTURE: Measuring frequency: 1 to 500 MHz.
 16093A BINDING POST FIXTURE: Distance between posts: approx. 7 mm. Measuring frequency: 1 to 250 MHz.
 16093B BINDING POST FIXTURE: Distance between posts: approx. 15 mm or 18 mm. Recommended measuring frequency: 1 to 125 MHz.
 16094A PROBE FIXTURE: Measuring frequency: 1 to 125 MHz.
PRICES IN U.S.A.: 4191A, \$14,260. Option 002, \$1680. Option 004, \$445.
MANUFACTURING DIVISION: Yokogawa-Hewlett-Packard Ltd.
 9-1, Takakura-cho, Hachioji-shi
 Tokyo, Japan, 192

input/output impedance of a transistor is easily done using this capability. The DUT port is extended with a coaxial airline and attached to the HP 11600B/116002B Transistor Fixture. Calibration is done at the input of the transistor fixture. Another practical but important application is temperature tests. By extending the DUT port with a precision APC-7 coaxial airline, the temperature characteristics of a DUT mounted in an oven may be taken. Maximum extendable length depends upon the measurement frequency and accuracy needed, but generally up to 1 m extension (approximately) is possible without significant degradation of the measurement accuracy.

Acknowledgments

Without the involvement and the efforts of many people,

this project could not have been successful. Team members who deserve special recognition are: Yukio Minami and Mitsuki Gotoh for analog circuit design, Jinichi Ikemoto and Takashi Yoshida for the digital section, Hiroshi Shiratori and Takashi Saitoh for mechanical design, Tsuneji Nakayasu for industrial design and test fixtures, and Hiroshi Sakayori for the hybrid sampler. Hitoshi Noguchi provided the framework. Special thanks are due to Masahide Nishida for his general management and encouragement.

Reference

1. K. Maeda and Y. Narimatsu, "Multi-Frequency LCR Meters Test Components under Realistic Conditions", Hewlett-Packard Journal, February 1979.

Hewlett-Packard Company, 1501 Page Mill Road, Palo Alto, California 94304

Bulk Rate
 U.S. Postage
 Paid
 Hewlett-Packard
 Company

HEWLETT-PACKARD JOURNAL

JANUARY 1980 Volume 31 • Number 1
 Technical Information from the Laboratories of
 Hewlett-Packard Company

Hewlett-Packard Company, 1501 Page Mill Road
 Palo Alto, California 94304 U.S.A.
 Hewlett-Packard Central Mailing Department
 Van Heuven Goedhartlaan 121
 1180 AM Amstelveen The Netherlands
 Yokogawa-Hewlett-Packard Ltd., Suginami-Ku
 Tokyo 168 Japan

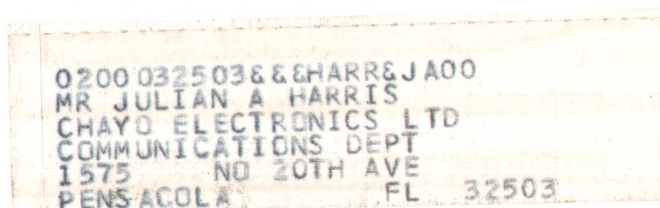

CHANGE OF ADDRESS: To change your address or delete your name from our mailing list please send us your old address label. Send changes to Hewlett-Packard Journal, 1501 Page Mill Road, Palo Alto, California 94304 U.S.A. Allow 60 days.